



Air Conditioners

Technical Data

VRV[®]

Water-cooled design guide



EEDEN12-201



Большая библиотека технической документации

<https://splitsystema48.ru/instrukcii-po-ekspluatácii-kondicionerov.html>

каталоги, инструкции, сервисные мануалы, схемы.



Air Conditioners

Technical Data



Water-cooled design guide



EEDEN12-201

TABLE OF CONTENTS

II Water-cooled design guide

1	Introduction.....	2
2	Basic configurations of VRV®-WIII.....	3
	Basic configuration for cooling operation.....	3
	Basic configuration for heating operation.....	4
	Alternative solution.....	5
3	Water piping elements.....	6
	Heat rejection equipment.....	6
	Heat transfer equipment.....	11
	Water pipes.....	12
	Expansion tank.....	15
	Pumps.....	15
	Temperature and pressure measurement points.....	16
	Water quality.....	17
4	System safety requirements.....	18
	Pump interlock.....	18
	Flow switch.....	18
	Anti freezing protection.....	19
	Water piping strainer.....	20
	Recommendations for multi outdoor unit installations.....	20
	The total heat rejection of a single unit is 710W.....	21
5	System control.....	22
	Complete control of a VRV®-WIII.....	22
	Interlocking VRV®-WIII outdoor units.....	22
6	Capacity correction factor.....	23
7	Refnet pipe systems.....	26
8	Refrigerant pipe selection.....	34
	Standard series.....	34
	Geothermal series.....	36
9	Typical VRV®-WIII installations.....	38
	Example Installation.....	38
	Example Installation.....	40
	Example Installation.....	42
	Example Installation.....	44

"Please note that this material is for reference only. In practice, construction methods may vary with projects and local legislation. Therefore, please consult your design office for design and construction of the system"

1 Introduction

The Daikin water cooled VRV[®] (VRV[®]-WIII) combines all the well known benefits of VRV[®] with those of water systems:

The VRV[®] component of the system - condensing and indoor units, refrigerant piping and controls - delivers high efficiency combined with exceptional control flexibility. Heat is exhausted or absorbed via the condensing units to and from the 2-pipe water circuit as required, during cooling and heating cycles respectively.

On the water side of the system the heat source (water) is supplied to VRV[®] condensing units throughout the building via the water circuit, which incorporates ancillary items such as - pumps, valves, strainer, expansion tank, heat transfer equipment, air vents and water treatment equipment etc.

The operating range of VRV[®]-WIII depends on the temperature of the water circuit, which should be maintained between 15°C and 45°C.

1

1

Application potential for VRV[®]-WIII:

- tall or wide multi storey buildings not subject to limitations on length of water piping
- applications in which the amount of refrigerant in the building is limited
- refurbishment projects in which it is possible to link VRV[®]-WIII into existing water piping and use the existing heat source
- sites where suitable alternative heat transfer sources such as district water, underground water, sea water, solar energy etc. exist
- sites where low external noise is critical. NB! Models of heat rejection equipment (cooling towers) are available for low noise applications.
- cold climate applications with no defrost cycle due to use of water circuit.

2 Basic configurations of VRV®-WIII

2 - 1 Basic configuration for cooling operation

In temperate climatic regions, excess heat within the water circuit can usually be exhausted via a dry cooler or cooling tower. However, alternative heat sinks can also be used, including natural water sources such as rivers, lakes and bore holes - existing process or chilled water circuits can also be utilized if fitted with heat transfer facilities.

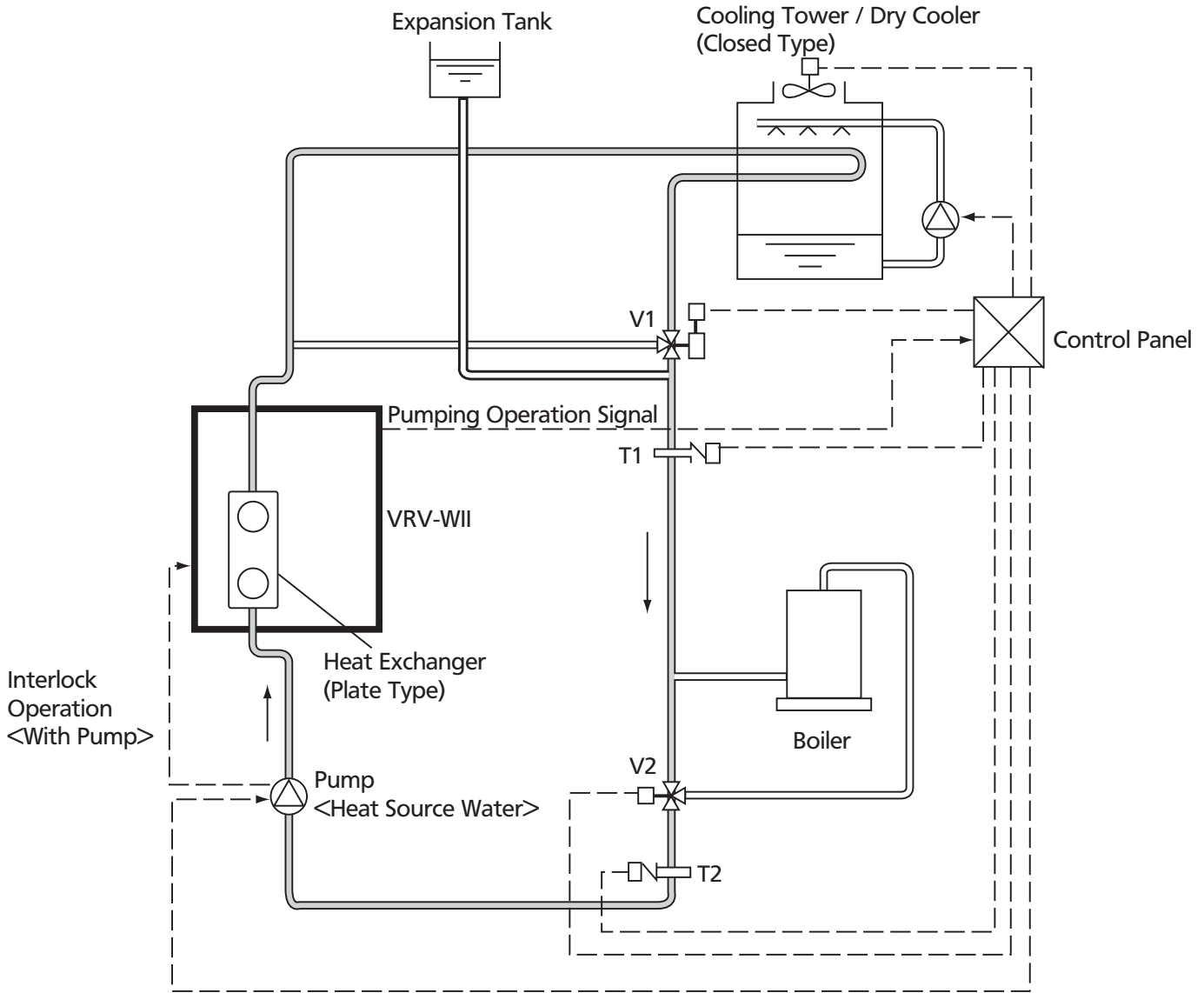

The diagram shows that during summer operating cycles, a drop in cooling water temperature below pre set temperature level T1 causes 3-way valve bypass V1 to open. This bypass closes once more when T1 is exceeded, reducing the temperature by allowing an increased flow of water to the cooling tower. On/off control of pump and fan in closed cooling tower circuits is also provided by 3-way valve, V1.

1
2

2 Basic configurations of VRV®-WII

2 - 2 Basic configuration for heating operation

Low pressure hot water from a boiler is generally utilized to maintain the required temperature levels within the water circuit - but steam, district/process/industrial heating systems or even solar energy can also act as the heat source.

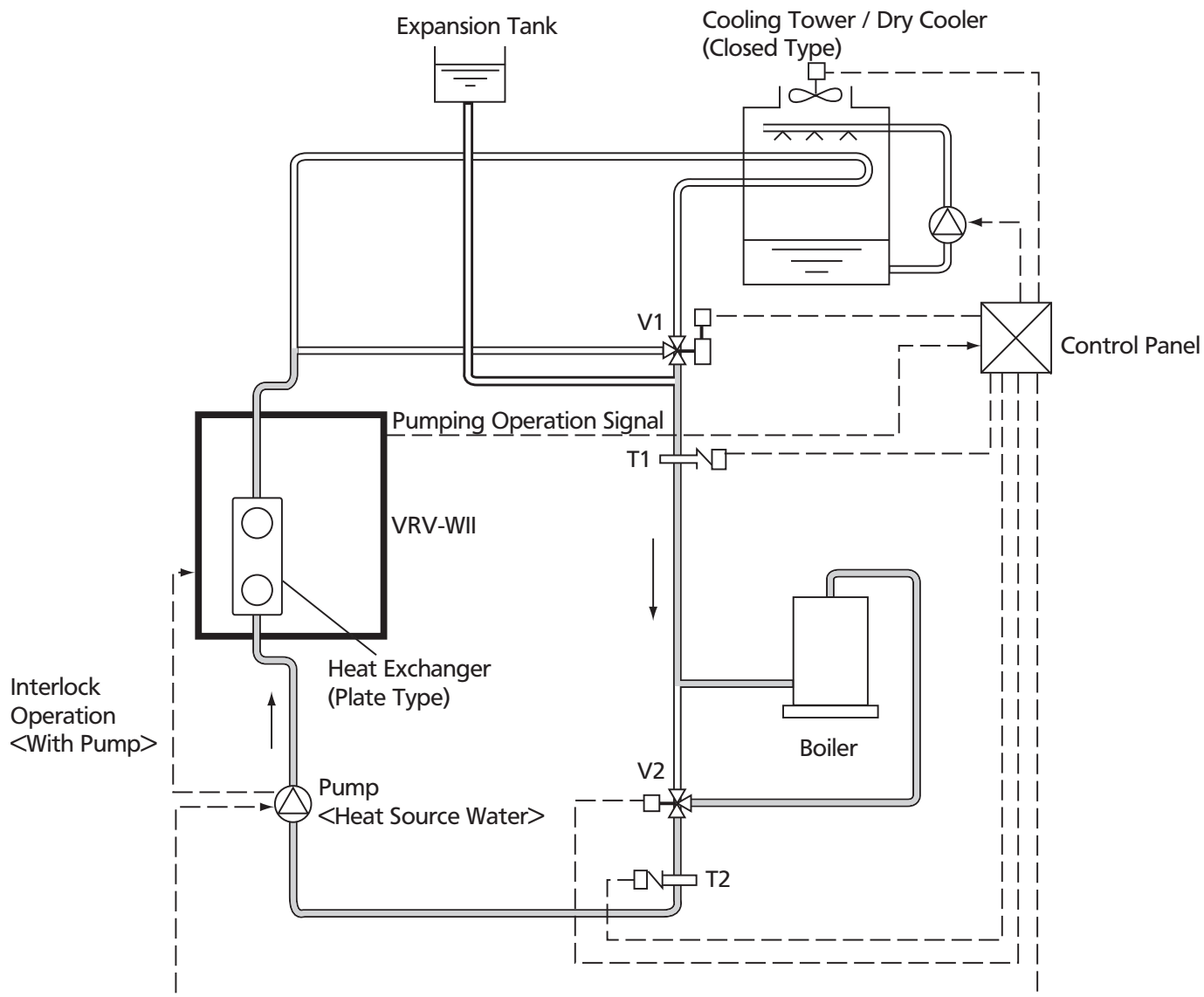

During winter operation, water circuit temperature T2 is maintained by circulating water through the boiler (or similar) via valve V2, which shuts off immediately the pre set temperature is achieved.

2 Basic configurations of VRV®-WIII

2 - 3 Alternative solution

Cooling tower and boiler replaced by heat pump chiller

The use of a boiler and cooling tower to maintain condenser circuit temperature can be replaced by a heat pump chiller in most Southern European regions, resulting in good control options via a single package, which can be supplied by Daikin.

The water circuit temperature on VRV®-WIII is outside the standard operating range of a standard heat pump chiller, hence the **pipng configuration is important**. All engineering data books for Daikin chillers publish the operating range and specify the max and min ΔT across the evaporator (Usually 3~8°C).

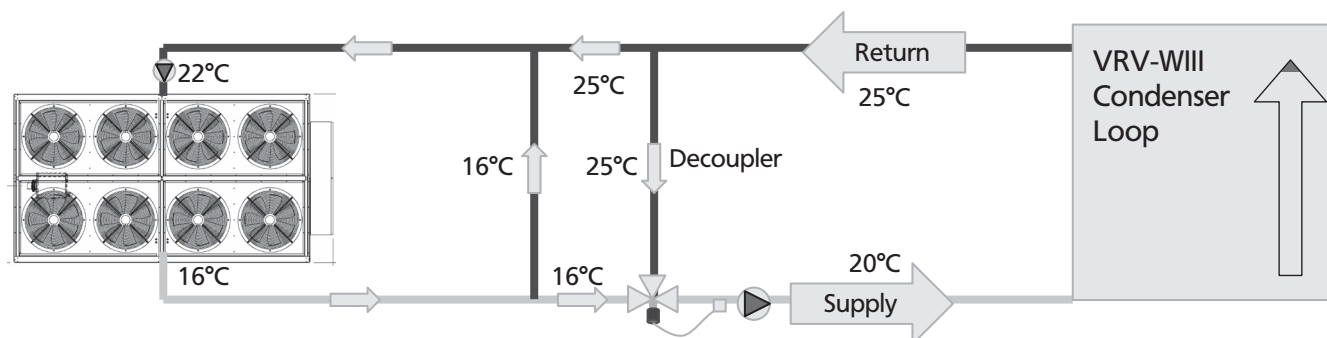

1
2

To ensure maximum operating efficiency of the heat pump chiller, the following data represents the optimum selection point when using the above configuration: -

- Cooling Mode: Leaving chilled water temperature
= **Highest possible leaving water temperature (16°C)**
- Heating Mode: Leaving hot water temperature =
= **Lowest possible leaving water temperature (25°C)**

3 Water piping elements

Water at the pre set temperature is supplied to all VRV®-VIII condensing units via a 2-pipe closed circuit..

Water temperatures within the circuit must be maintained at 15 to 45°C and pumps should be of sufficient duty to match the requirements of all VRV®-VIII condensing units. Air purging should be carried out in closed circuit systems and a strainer installed to prevent impurities from entering the water flow. Expansion tanks are also important since they allow for temperature changes within the circuit. System start up should be provided by a controller, which also regulates circuit water temperature and protects the system.

Steel, stainless steel, copper and plastic but not galvanised, piping can be used.

1
3

1 When designing a water piping system, the following should be considered:

- water must be supplied to the required locations according to the needs of each VRV®-VIII
- head and friction losses should be kept at a minimum
- water velocity should be properly controlled to avoid water streaming noise, pipe vibration or pipe expansion/contraction due to temperature differences.
- attention should be paid to water management: impact of the water quality, corrosion prevention...
- enough arrangements should be provided for easy service and maintenance.

3 - 1 Heat rejection equipment

In cooling mode, the purpose of the water cooled VRV® plant is to reject unwanted heat outdoors.

In an **air cooled VRV®III**, cooler ambient air is usually drawn across the condenser coil by means of propeller fans. High pressure refrigerant heat is transferred to the cooler ambient air and exhausted outdoors.

By comparison, in a **water cooled VRV®-VIII**, cooling water is pumped through the plate type condenser. High pressure refrigerant heat is transferred to the cooler condenser water and exhausted outdoors.

3 - 1 - 1 Cooling towers types

The cooling tower is still the most common equipment used for water heat rejection. With the current drive towards energy efficiency, ground water, lakes, rivers and sea have been used as an alternative heat rejection medium. Environmental concerns and restrictions however, may limit this potential source.

The cooling tower relies on the process of evaporation, enabling the condenser water circuit to be cooled to a temperature below the ambient wet bulb.

1 Cooling tower performance is dependent on the ambient wet bulb, whilst dry bulb temperature has little effect on performance.

Over sizing cooling towers will lead to lower condenser water temperatures at part load operation, increasing plant efficiency.

Cooling towers are either of the "**open**" or "**closed**" type.

In an **open tower**, the condenser water / fluid circuit comes into direct contact with the outside air.

In a **closed tower**, the condenser water is circulated in the heat exchanger tubes, while an evaporating water film falls on the fins of the tube exchanger.

3 Water piping elements

3 - 1 Heat rejection equipment

3 - 1 - 1 Cooling towers types

3 - 1 - 1 - 1 Open cooling towers

Open cooling towers are classified in terms of the airflow configuration. **"Forced draught"** and **"induced draught"** towers are the most common types found in the HVAC industry. The forced draught tower is driven by a fan, which blows air through the tower. Induced draught towers **pull** the air through the tower.

Depending on whether the air is drawn against the flow of the water or across the flow of water in the tower, the systems can be further classified as **"counter flow"** or **"cross flow"** configurations.

① Induced draught tower

This type of unit utilizes axial flow fans and is generally thought to be the most efficient and therefore the most popular, in use today.

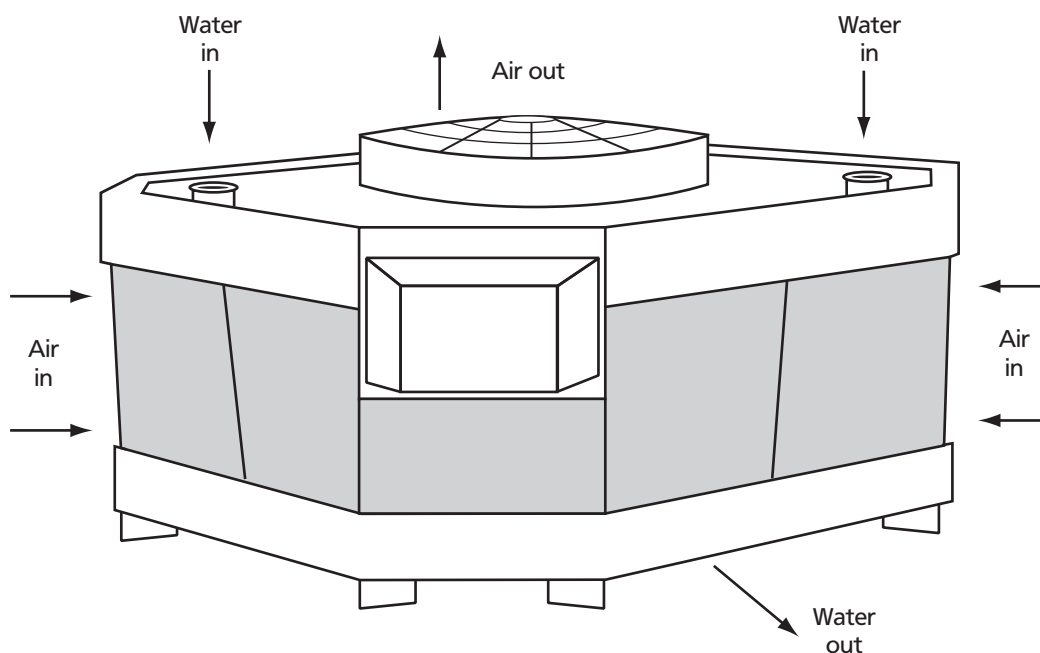

Large propeller fans on the air discharge or the top of the tower **draw air counter flow or cross flow** to the condenser water. Due to the higher discharge velocities they are less susceptible to short air circuits or recirculation. Noise levels are higher due to the low frequency noise associated with propeller and axial fans.

3 Water piping elements

3 - 1 Heat rejection equipment

3 - 1 - 1 Cooling towers types

3 - 1 - 1 - 1 Open cooling towers

① Forced Draught Tower

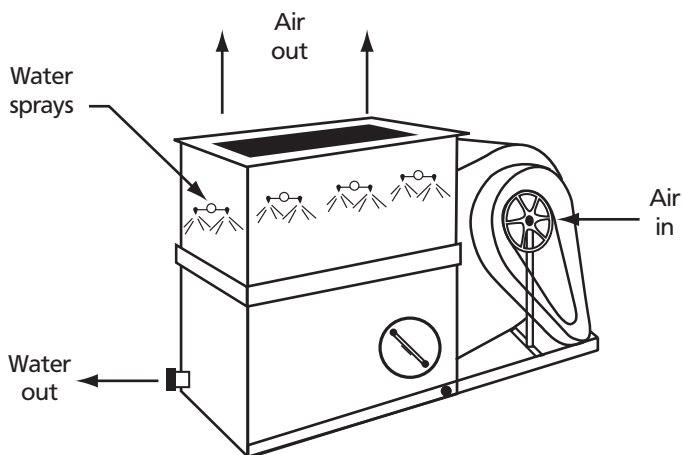

Forward curved centrifugal fans on the air inlet will **force/push** the air in either a counter flow or cross flow pattern. **Centrifugal fans use more power but generate enough static pressure to overcome any problems associated with internally located cooling towers or those fitted with sound dampers.** These towers are quieter than others and are particularly useful for low noise applications. The cross flow tower offers the benefit of a lower profile unit where aesthetics or plant room height may be restricted. On the other hand, the power input is approximately double that of an induced draught tower.

Typical air/water temperatures for an open cooling tower operating in a temperate climatic region:

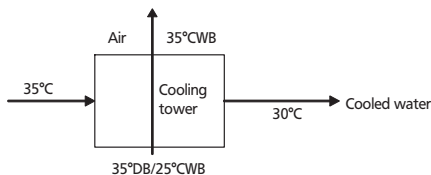

3 Water piping elements

3 - 1 Heat rejection equipment

3 - 1 - 1 Cooling towers types

3 - 1 - 1 - 2 Closed cooling towers

The water being cooled is contained within a heat exchanger or coil.

Numerous advantages are associated with this arrangement, particularly if the water is pressurized or mixed with chilled water from an external source or if the primary pump is sited away from the cooling tower.

Closed cooling towers tend to be larger than open models and consequently, more expensive.

On the other hand, since fouling is negligible, closed type systems have lower maintenance costs

There are 2 types:

① **Evaporative cooling tower:**

A secondary open water spray system is used to distribute a film of water to the fins to provide the benefit of evaporative cooling.

② **Dry cooler:**

The concept is similar to that of an air cooled condenser with condenser water circulating through the tubes and is therefore classed as a closed type system. Due to the higher condenser water temperatures of dry coolers, performance is similar or lower than an equivalent air cooled package.

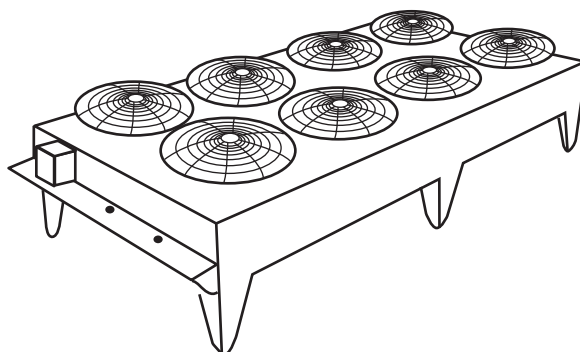

Typical air/water temperatures for a dry cooler tower operating in a temperate climatic region:

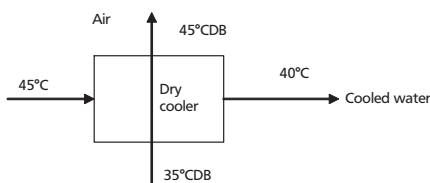

RECOMMENDATION

- 1 It is recommended that closed cooling towers should be used as much as possible in order to prevent the cooling water from becoming contaminated.
- 2 When open cooling towers are used it is essential to install a water treatment system.

3 Water piping elements

3 - 1 Heat rejection equipment

3 - 1 - 2 Cooling tower selection

Cooling tower selection is based on the amount of heat to be rejected (the actual cooling capacity + compressor power) and the optimum method of rejecting this heat depending on the most important design criteria, ie. initial cost, efficiency, footprint and noise.

Example of selection of a dry cooler:

Q_r = total rejected heat = Total (cooling capacity + PI) of VRV®-WIII units (kW)

m = VRV®-WIII total condenser flow rate (kg/s)

ΔT = range = LWC-EWC (°C)

LWC = Condenser leaving water temperature

EWC = Condenser entering water temperature

1
3

$$\Delta T = Q_r / (4.2 \times m)$$

where 4.2 = specific heat capacity, kJ/kg*s

LWC is pre-selected within the limits of the VRV®-WIII operation range (15°-45°C), EWC is calculated.

With these values, the dry cooler can be selected by using different manufacturers' selection catalogues or software.

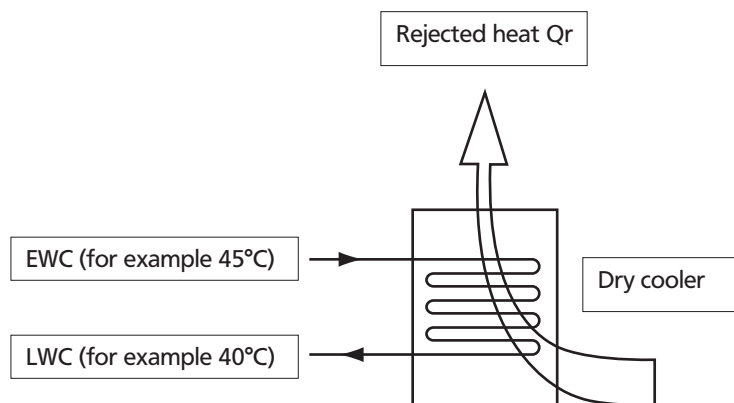

3 Water piping elements

3 - 2 Heat transfer equipment

An external heat source, usually in the form of a LPHW boiler and associated heat exchanger is necessary in applications in which the operating temperature of the water circuit cannot be maintained due to insufficient heat recovery within the system. The operating temperature of the boiler should be in the region of 90/70°C.

Example of boiler selection:

Boiler selection is carried out similarly to cooler selection, except the kW of power input (PI) is subtracted from instead of added to the VRV®-WIII heating capacity.

Q_i = total injected heat = total (heating capacity - PI) of VRV®-WIII units (kW)

m = VRV®-WIII total condenser flow rate (kg/s)

ΔT = EWC-LWC (°C)

LWH = heat exchanger leaving water temperature

EWH = heat exchanger entering water temperature

$$\Delta T = Q_i / (4.2 \times m)$$

where 4.2 = specific heat capacity, kJ/kg*s

LWH is pre-selected within the limits of the VRV®-WIII operation range (15°-45°C), EWH is calculated.

Based on total injected heat (Qi), the boiler can be selected.

With these values, the heat exchanger can also be selected by using different manufacturers' selection catalogues or software.

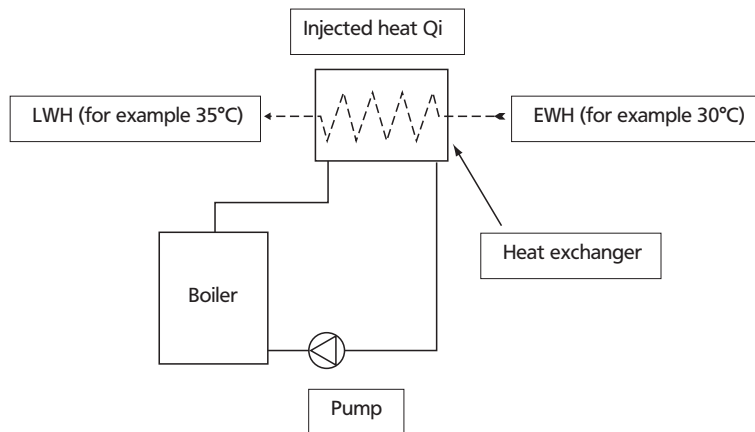

3 Water piping elements

3 - 3 Water pipes

The 2-pipe layout is commonly used and consists out of one pipe to and one from the terminal (fan coil unit or VRV®-WIII). Both chilled or hot water can be supplied to the terminal.

3 - 3 - 1 Reverse return method for dimensioning the water pipes:

According to this method, the length of the water piping return and supply is almost equal for all VRV®-WIII condensing units in the system. The friction loss is almost the same, resulting in a balanced water flow to each condensing unit. Adversely, the piping length is longer. Since the water circuits are equal for each unit, the major advantage of the reverse return method is that it seldom requires balancing. Due to the more balanced flow, the test run and maintenance work becomes easier.

It is often the most economical design for new build projects.

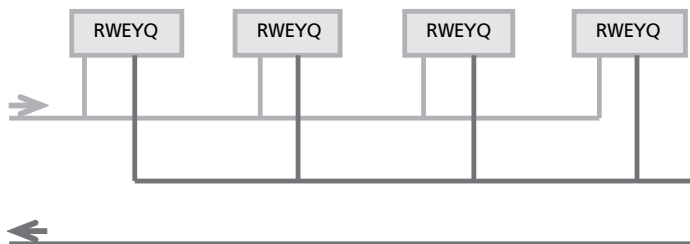

3 - 3 - 2 Friction losses

In order to force a fluid through a pipe, pressure is required to overcome the viscous friction forces. Friction loss occurs when water flow through a pipe.

NOTE

- The Darcy equation is the basis of all fluid flow equations and relates the pipe pressure drop required to overcome the fluid viscous friction forces:

$$\partial P = (\rho * f * l * v^2) / (2 * d)$$

Where: ∂P = friction losses (Pa)

ρ = fluid density (kg/m³)

f = friction factor, depending on the roughness of the internal surface of the pipe (dimensionless)

l = pipe length (m)

v = fluid velocity (m/s)

d = internal pipe diameter (m)

Most air conditioning systems use steel pipe or copper tubing .

Based on the Darcy equation, the pipe friction / flow tables are made (e.g. fig.1).

3 - 3 - 3 Water velocity

The recommended water velocity through the piping is depending on two conditions:

- pipe diameter
- effect of erosion.

The table below lists the recommended velocity ranges for the different piping diameters. The higher the water velocity, the higher the noise level of the moving water and the entrained air and the erosion will be.

Recommended water velocity	
Diameter (mm)	Velocity range (m/s)
> 125	2.1 ~ 2.7
50-100	1.2 ~ 2.1
about 25	0.6 - 1.2

Since erosion is a function of time, water velocity and quality of water, the design water velocity is subject to the judgment of the design engineer.

3 Water piping elements

3 - 3 Water pipes

3 - 3 - 4 Example of dimensioning the water pipes:

Preliminary information on the VRV®-WIII systems, according with capacity tables:

- **system 3rd floor: 30 HP**
 - 130% connection ratio
 - water flow: $96 \times 3 = 288 \text{ l/min}$
 - water temp inlet/outlet: $30^\circ\text{C}/34,3^\circ\text{C}$
- **system 2nd floor: 10 HP**
 - 120% connection ratio
 - 96 l/min
 - $30^\circ\text{C}/34^\circ\text{C}$
- **system 1st floor: 10 HP**
 - 120% connection ratio
 - 96 l/min
 - $30^\circ\text{C}/34^\circ\text{C}$
- **basement: 20 HP**
 - 120% connection ratio
 - $96 \times 2 = 192 \text{ l/min}$
 - $30^\circ\text{C}/34^\circ\text{C}$

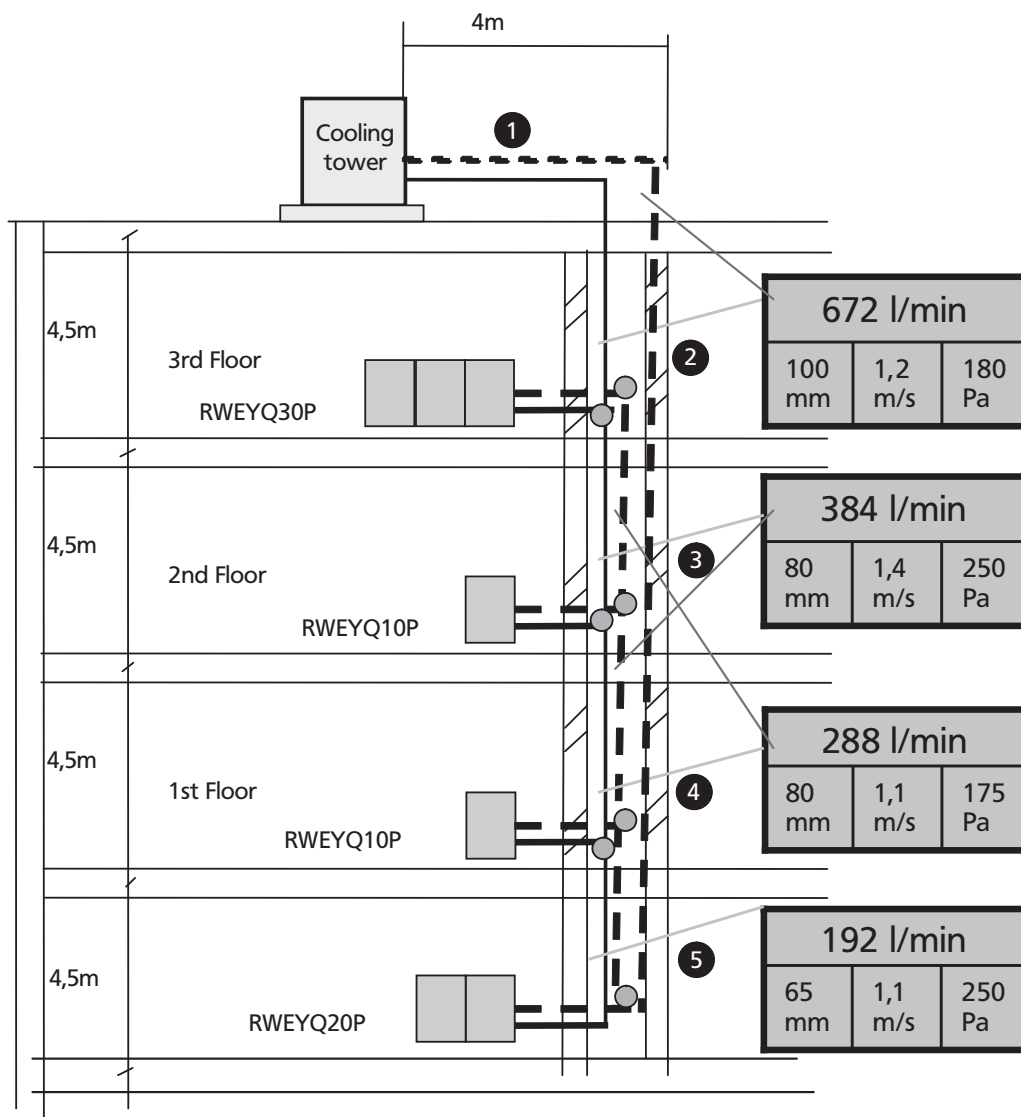

3 Water piping elements

3 - 3 Water pipes

3 - 3 - 4 Example of dimensioning the water pipes:

RECOMMENDATION

- 1 in VRV®-VIII capacity tables 4 water flows are mentioned for each model/connection ratio: 50, 60, 96, 120 l/min
- 2 water flows of either 60 or 96 l/min are advisable in order to maintain a balance between pipe diameter and pressure losses. As water flow increases, pipe diameter reduces whereas pressure losses increase with increased water flow.

1
3

Black Steel Pipe

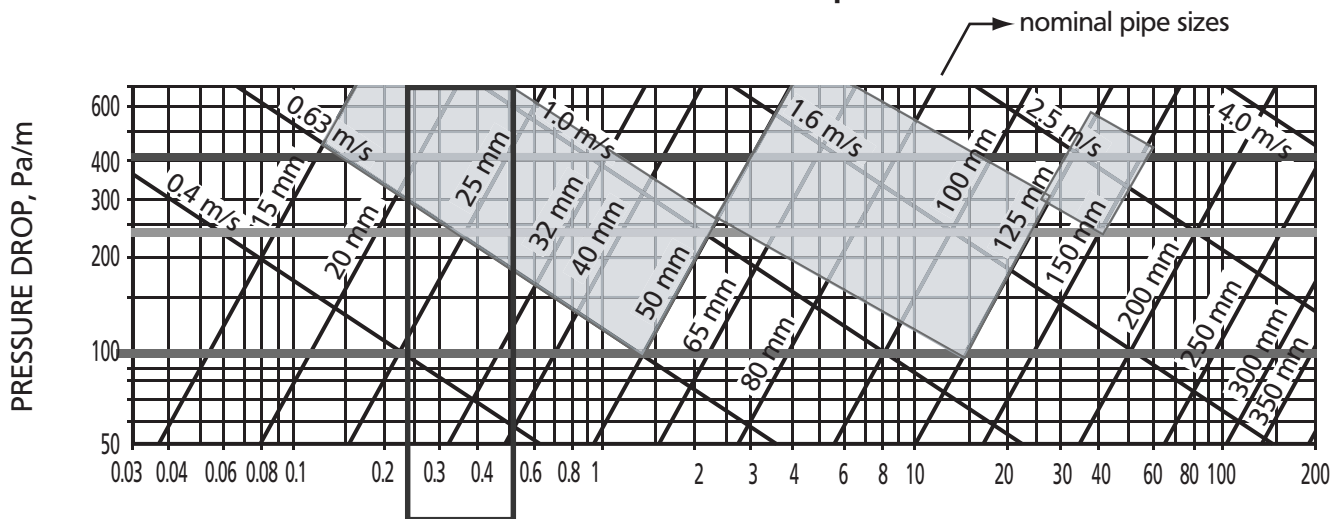

Fig. 1 VOLUMETRIC FLOW RATE, L/s

Friction Loss for Water in Commercial Steel Pipe

Procedure for pipe selection:

- reverse return piping was chosen
- the water flow should be determined for each section of the water circuit
- by means of the using the friction loss diagram (fig.1), the diameter should be determined based on following input:
 - water flow
 - recommended domain of water velocities
 - recommended domain of linear pressure losses (100-400 Pa/m)
- the total linear friction losses should be determined by multiplying the pressure drop (Pa/m) obtained from the diagram, with the pipe length.
- local pressure losses should be calculated for special fittings like elbows, T-connections, reducers, etc. The values can be obtained from pipe manufacturers' catalogues. The following table can be also used: the equivalent length should be multiplied with the pressure drop (Pa/m) determined before.

Equivalent length of local friction loss (m)

Nominal pipe size	mm	15	20	25	32	40	50	65	80
	in	1/2	3/4	1	1 1/4	1 1/2	2	2 1/2	3
Elbow		0.5	0.6	0.9	1.1	1.3	1.6	2.1	2.6
T-connection straight through		0.3	0.4	0.6	0.8	0.9	1.1	1.4	1.7
T-connection through branch		1.0	1.3	1.8	2.3	2.8	3.5	4.2	5.7
Gate valve		0.1	0.15	0.2	0.3	0.35	0.4	0.5	0.6
Reducer (3/4)		0.1	0.15	0.2	0.3	0.35	0.4	0.5	0.6
Globe valve		4.5	6.5	9.0	11	16	21	26	30

- total friction loss in pipes should be calculated by adding the linear and local friction losses.

The total friction loss in pipes will serve further when selecting the circulating pump.

3 Water piping elements

3 - 4 Expansion tank

The purpose of the expansion tank is to maintain system pressure by allowing the water to expand when the water temperature increases in order to prevent pipes from bursting. It also provides the means for adding water to the system

An expansion tank is required in a closed system. In an open system, the reservoir acts as the expansion tank.

The expansion tank can be of the open or closed type.

The **open expansion tank** (reservoir) is located at the suction side of the pump, above the highest point in the system. At this location, the tank provides atmospheric pressure equal to or higher than the pump suction, preventing air from leaking into the system.

The **closed expansion tank** is used in small systems and work at atmospheric pressure. The tank is located at the suction side of the pump.

The capacity of a closed expansion tank is greater than that of an open expansion tank operating under the same conditions.

When sizing the expansion tank, the engineering supplied by the tank manufacturer should be consulted.

3 - 5 Pumps

Centrifugal pumps are the most commonly used types in chilled water (CW) and low pressure hot water circuits (LPHW).

An electric motor usually powers the impeller (the rotating specially shaped "heart" of the pump) rotation.

System design requires a duty and a standby pump to be selected for the sum of all water flow rates of the VRV®-WIII system.

Pump performance can be given in terms of discharge capacity, head, shaft, power and efficiency

- **The discharge capacity** is the required water flow rate (m³/min or l/min). The correlation between the pump suction size and the water flow is listed in table.

Correlation between pump suction size and water flow rate	
Suction size (mm)	Discharge capacity (m ³ /min)
40	0.10~ 0.20
50	0.16~ 0.32
65	0.25~ 0.50
80	0.40~ 0.80
100	0.63~ 1.25
125	1.00~ 2.00
150	1.60~ 2.15
200	2.50~ 5.00
250	4.00~ 8.00
300	3.30~12.50

- **The head is the pressure produced by the pump** in metres of water column. The higher the discharge capacity of the pump, the lower the head (Fig. 2).
- **The required pump power** is roughly proportional to the delivered capacity.
- **The pump efficiency (%)** is defined as the ratio between the delivered work and the shaft power: **efficiency % = (power output / power input) x 100%**
- **The pump efficiency may be obtained from manufacturer data.**

The pump performance chart is the summary of the head, efficiency and discharge capacity.

The pump is operated at the intersection between the head and the system resistance curve. This intersection is called the pump operating point.

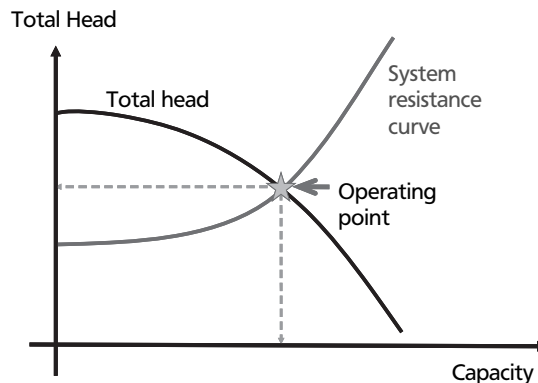

Fig. 2

3 Water piping elements

3 - 5 Pumps

NOTE

- When the gate valve is throttled, the resistance increases and the water flow rate decreases. In doing this, the operating point can be changed. The same phenomena, a decrease in water flow rate and an increase in the head loss, can be caused when rust and / or scale is deposited on the internal surface of the water piping system.

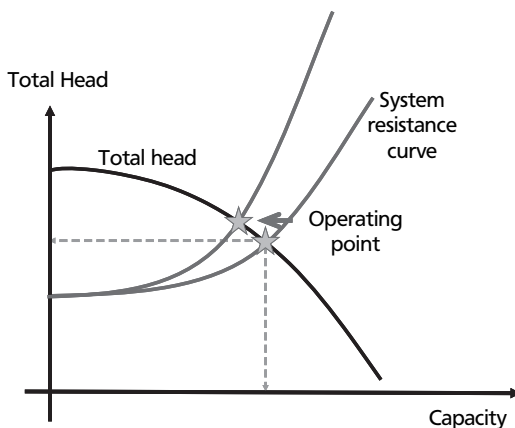

The pump selection can be carried out through calculation or by use of the pump selection chart:

- The input valves are:
 - design flow rate (discharge capacity)
 - total friction loss (system resistance)
 - the pump efficiency
- The type of pump and required power of the pump are resulting.

In both cases the maximum friction loss (usually the longest pipe branch in the piping system) should be calculated:

$$H = H_a + H_f + H_t + H_k$$

Where: **H** = total friction loss

H_a = actual head (mH₂O) = difference between the discharge and suction level

H_f = linear friction loss in straight pipes (mH₂O) = from friction loss diagram

H_t = local friction loss (mH₂O) caused by fittings = equivalent piping length * basic friction loss

H_k = internal friction loss (mH₂O) of evaporator/condenser (of the cooling tower and VRV®-WIII) may be obtained from the manufacturer's data.

3 - 6 Temperature and pressure measurement points

Temperature and pressure measurement points should be located at each VRV®-WIII condensing unit

3 Water piping elements

3 - 7 Water quality

Be sure the water quality is in accordance with the specifications below:

Water quality standards for chilled water, hot water and make-up water

ITEM (5)	Cooling water system (3)		Hot water system (2)		Tendency (1)	
	Circulation system		Circulation water (20°C ~ 60°C)	Make-up water	Corrosion	Scale
	Circulation water	Make-up water				
Standard items						
pH (25°C)	6.8 to 8.2	6.0 to 8.0	7.0 to 8.0	7.0 to 8.0	○	○
Electrical conductivity (mS/m) (25°C)	Less than 80	Less than 30	Less than 30	Less than 30	○	○
Chloride ions (mg Cl ⁻ /l)	Less than 200	Less than 50	Less than 50	Less than 50	○	
Sulfate ions (mg SO ₄ ²⁻ /l)	Less than 200	Less than 50	Less than 50	Less than 50	○	
Acid consumption (pH 4.8) (mg CaCO ₃ /l)	Less than 100	Less than 50	Less than 50	Less than 50		○
Total hardness (mg CaCO ₃ /l)	Less than 200	Less than 70	Less than 70	Less than 70		○
Calcium hardness (mg CaCO ₃ /l)	Less than 150	Less than 50	Less than 50	Less than 50		○
Ionic-state silica (mg SiO ₂ /l)	Less than 50	Less than 30	Less than 30	Less than 30		○
Reference items						
Iron (mg Fe/l)	Less than 1.0	Less than 0.3	Less than 1.0	Less than 0.3	○	○
Copper (mg Cu/l)	Less than 0.3	Less than 0.1	Less than 1.0	Less than 0.1	○	
Sulfite ion (mg S ²⁻ /l)	Shall not be	Shall not be	Shall not be	Shall not be	○	
Ammonium ion (mg NH ₄ ⁺ /l)	Less than 1.0	Less than 0.1	Less than 0.3	Less than 0.1	○	
Residual chlorine (mg CL/l)	Less than 0.3	Less than 0.3	Less than 0.25	Less than 0.3	○	
Free carbon dioxide (mg CO ₂ /l)	Less than 4.0	Less than 4.0	Less than 0.4	Less than 4.0	○	
Stability index	6.0 to 7.0	-	-	-	○	○

1
3

4 System safety requirements

4 - 1 Pump interlock

Problems can arise if the VRV®-WIII condensing units are allowed to operate without sufficient water within the circuit.

When interlocking a water pump with a VRV®-WIII system, terminals 1 and 2 of the X2M terminal strip should be used.

The PCB of the VRV®-WIII condensing unit:

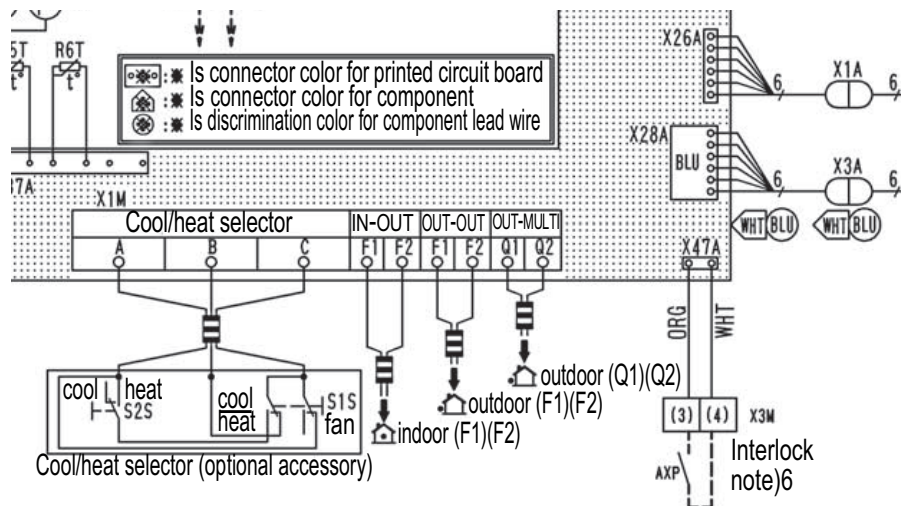

NOTE

1 In most cases in large buildings (20,000 m²) the pumps run continuously. Therefore the interlock function is not used.

4 - 2 Flow switch

A flow switch per VRV®-WIII module is recommended to ensure that each module receives its required flow rate. If one flow switch is open, the module stops. In case of a multi arrangement (20 and 30 HP units), all units in the same system will remain in 'off' condition, which will continue as long as any VRV®-WIII module detects an 'open' status for a flow switch.

A flow switch can be interlocked between the terminal 3 and 4 of the terminal strip X3M

4 System safety requirements

4 - 3 Anti freezing protection

Anti freezing protection should be provided for the cooling tower and the external water piping during winter

Typical measures:

- if the temperature drops, **the pump** should be started to re-circulate the water
- electric heater tape should be used
- a forced boiler start up program activated
- water should be drained from the cooling tower

4 - 3 - 1 Glycol application

The use of a certain % ethylene glycol instead of normal water will affect the COP and water flow rate of the system, together with pressure drop on total system.

Glycol should be limited in use, however when necessary a primary and secondary water loop is recommended (Fig 3)

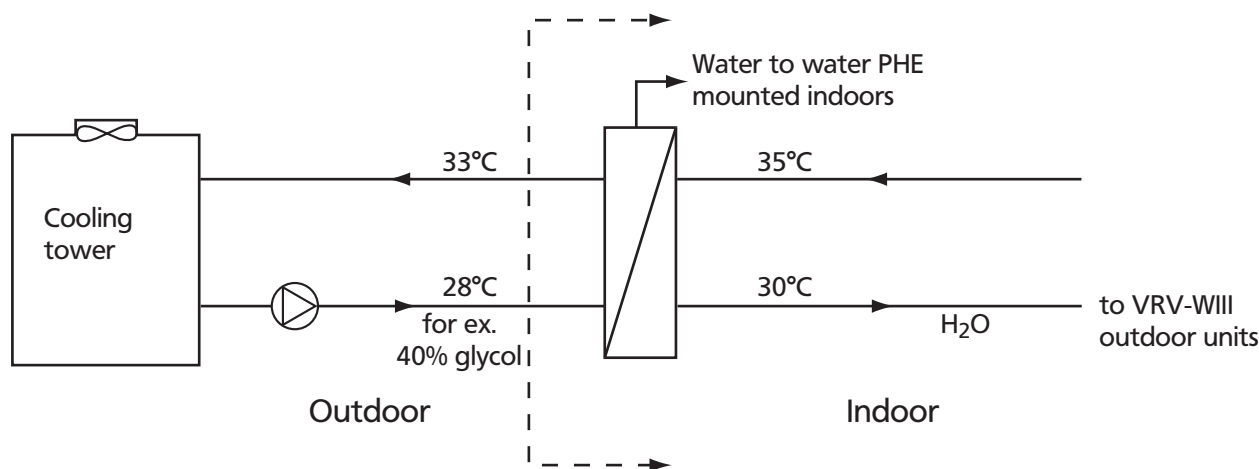

Fig. 3

Example

① **Influence on COP:**

- When normal water is used -
Cooling operation: capacity 26.7kW, power input: 6.07kW
Heating operation: capacity 31.5kW, power input: 6.05kW
- When ethylene glycol 40% is used
Cooling operation: capacity 26.1kW, power input: 6.35kW
Heating operation: capacity 31.5 kW, power input: 6.30kW

③ **Water flow range:**

- When using normal water: from 50 l/min to 120 l/min
- When using water with 40/% glycol: from 80 l/min to 150 l/min
Larger piping diameters are required.

④ **Water temperature range: between 15°C and 45°C, the same as for normal water.**

⑤ **Corrosiveness:**

Since the heat exchanger is made of SUS304, anti-freezing fluid non corrosive to SUS304 must be used.

4 System safety requirements

4 - 4 Water piping strainer

A strainer kit 50 mesh should be provided for each outdoor unit in order to filter the water and protect the VRV®-VIII heat exchanger against dirt.

Why the strainer a must

- 1 A plate heat exchanger consists of several water passages in parallel.
- 2 If no water filter is used, some of these passages can get blocked by dirt.
- 3 Evaporating temperature drops but the mix of water temperatures of the non blocked passages remains above freezing point.
- 4 The water in the blocked passages starts to freeze and the PHE breaks.
- 5 The result is a leak between the water circuit and the refrigerant circuit.

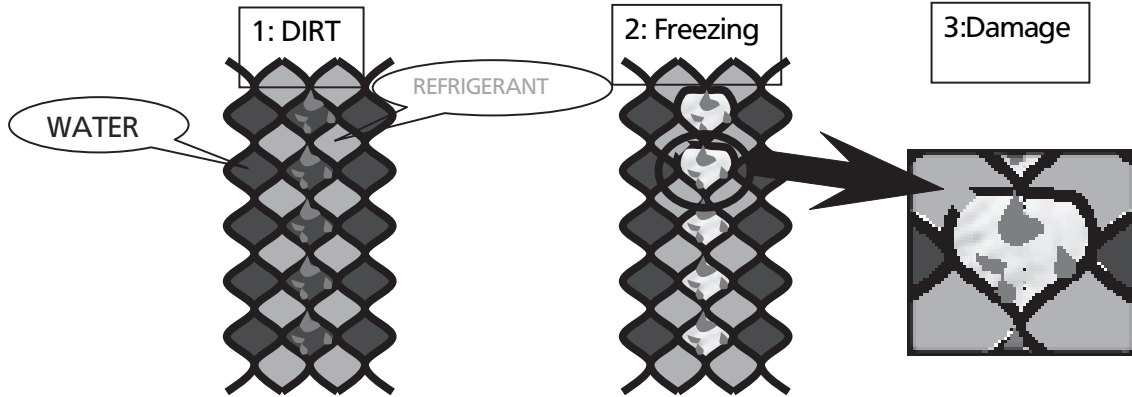

4 - 5 Recommendations for multi outdoor unit installations

Recommendations for multi outdoor unit installations, in order to prevent oil and refrigerant flow back to a stopped outdoor unit:

- An oil trap of 200 mm or more should be located on the gas pipe
- At every 2m of piping between outdoor units, an oil trap of 200mm should be fitted on the gas pipe.
- Piping between outdoor units should be horizontal or upwards inclined.

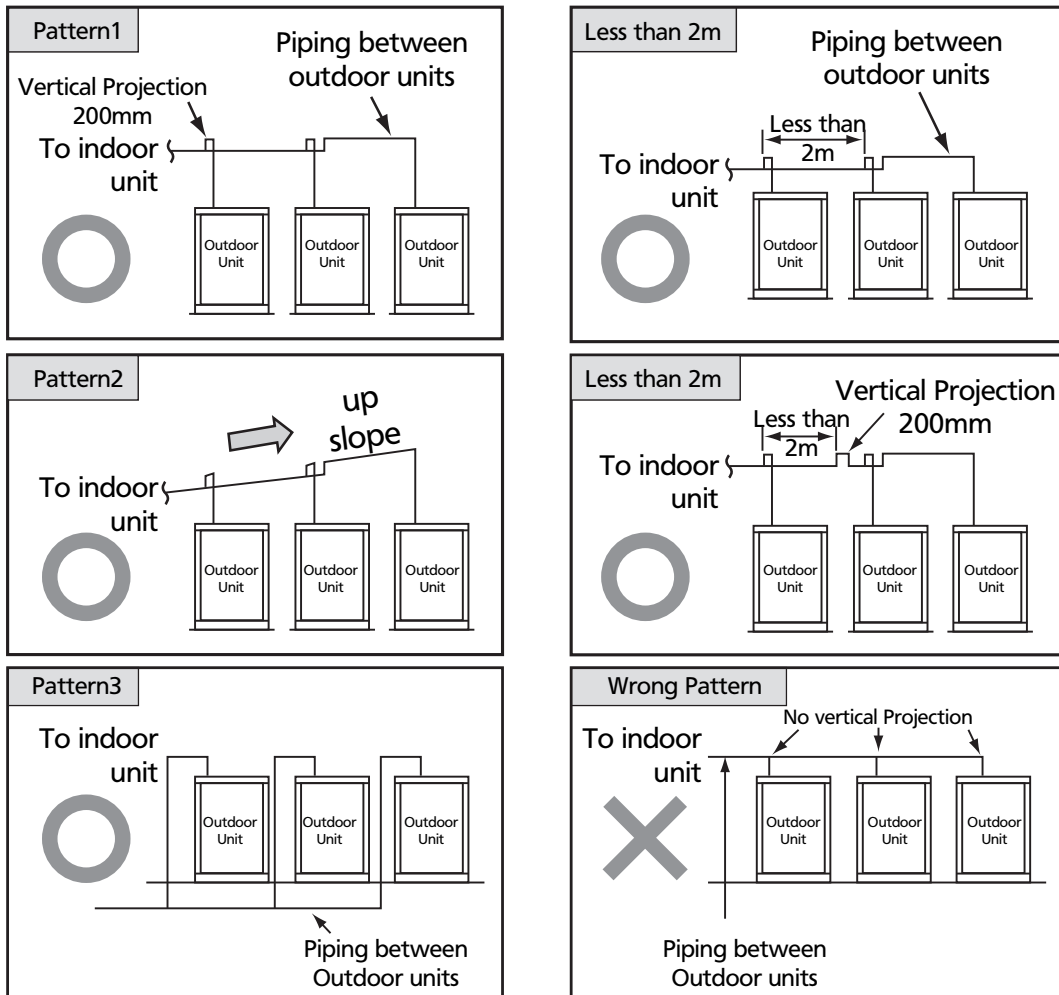

4 System safety requirements

4 - 5 Recommendations for multi outdoor unit installations

- A straight refrigerant pipe of 500mm should be positioned in front of the Y branch kit which couples outdoor unit piping.

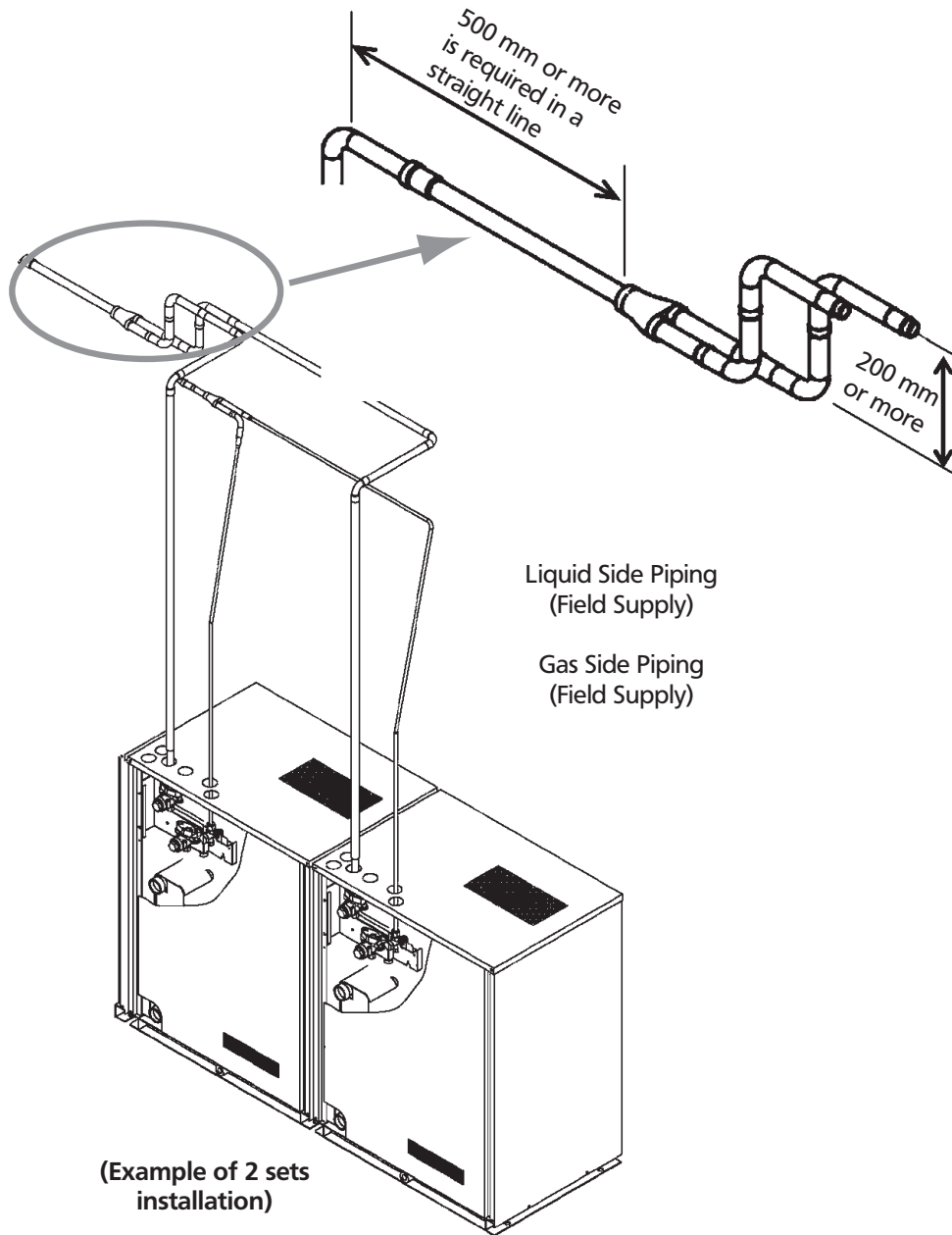

4 - 6 The total heat rejection of a single unit is 710W.

The majority of heat produced will be from the inverter board and compressor, which is why the machine room must be ventilated, especially if the ambient temperature is over 40°C. A space of 300 mm must be allowed above the unit for heat rejection.

5 System control

5 - 1 Complete control of a VRV®-WIII

- The control for the refrigerant side is identical to that of an air cooled VRV®III -- by the use of the DIII communication line

Complete control of a VRV®-WIII system (including pumps and cooling tower) can be achieved by using Intelligent Controller and Intelligent Manager:

For ex.:

The on/off control of water pumps, cooling water fan and pumps can be controlled via the DEC101A51 (digital input) or DEC102A51 (digital input/output) electronic boards.

More details can be found in the chapters of the control systems data books.

5 - 2 Interlocking VRV®-WIII outdoor units

Centralized interlocking input to multiple condensing units is possible by using an external control adaptor (DTA104A62)

1

5

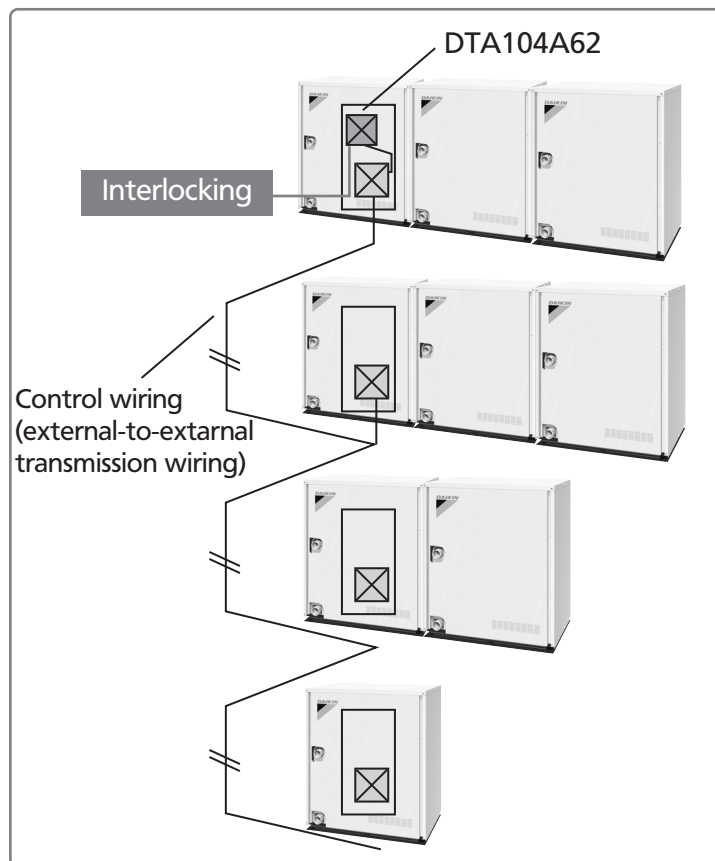

6 Capacity correction factor

RWEYQ8P

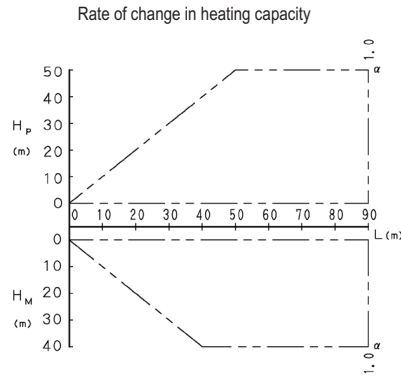
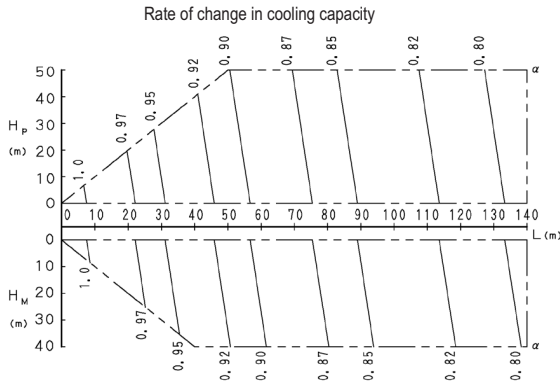

3D062332A

NOTES

- These figures illustrate the rate of change in capacity for a standard indoor unit system at maximum load (with the thermostat set to maximum) under standard conditions. Moreover, under partial load conditions, there is only a minor deviation from the rate of change in capacity shown in the above figures.
- With this outside unit, evaporating pressure constant control when cooling and condensing pressure constant control when heating is carried out.
- Method of calculating A/C (cooling/heating) capacity:
The maximum A/C capacity of the system will be either the total A/C capacity of the indoor units obtained from capacity characteristic table or the maximum A/C capacity of outside units as mentioned below, whichever smaller.

Calculating A/C capacity of outside units

- Condition: Indoor unit combination ratio does not exceed 100%.

$$\text{Maximum A/C capacity of outside units} = \left[\frac{\text{A/C capacity of outside units obtained from capacity characteristic table at the 100\% combination}}{\alpha} \right] \times \left[\text{Capacity change rate due to piping length to the farthest indoor unit} \right]$$

- Condition: Indoor unit combination ratio exceeds 100%.

$$\text{Maximum A/C capacity of outside units} = \left[\frac{\text{A/C capacity of outside units obtained from capacity characteristic table at the combination}}{\alpha} \right] \times \left[\text{Capacity change rate due to piping length to the farthest indoor unit} \right]$$

- When overall equivalent pipe length is 80m or more, the diameter of the main liquid pipes (outside unit-branch sections) must be increased.

Model	Liquid pipe
RWEYQ8P	Ø12.7

- Read cooling/heating capacity rate of change in the above figures based on the following equivalent length

$$\text{Overall equivalent length} = (\text{equivalent length to main pipe}) \times \text{Correction factor} + (\text{Equivalent length after branching})$$

Choose a correction factor from the following table.

- When cooling capacity is calculated: gas pipe size
- When heating capacity is calculated: liquid pipe size.

Rate of change (object piping)	Correction factor	
	Standard size	Size increase
Cooling (gas pipe)	1.0	—
Heating (liquid pipe)	1.0	0.5

(Example) RWEYQ8PY1

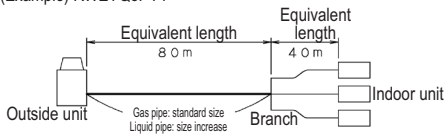

In the above case

(Cooling) Overall equivalent length = 80m x 1.0 + 40m = 120m

(Heating) Overall equivalent length = 80m x 0.5 + 40m = 80m

The correction factor is:

cooling capacity when H_p = 0m is thus approximately 0.81

heating capacity when H_p = 0m is thus approximately 1.0

6. Explanation of symbols

- H_p: Level difference (m) between indoor and outside units where indoor unit in inferior position
 - H_M: Level difference (m) between indoor and outside units where indoor unit in superior position
 - L: Equivalent pipe length (m)
 - α: Capacity correction factor
- Diameter of pipes

Model	Liquid pipe
RWEYQ8P	Ø9.5

6 Capacity correction factor

RWEYQ10,20P

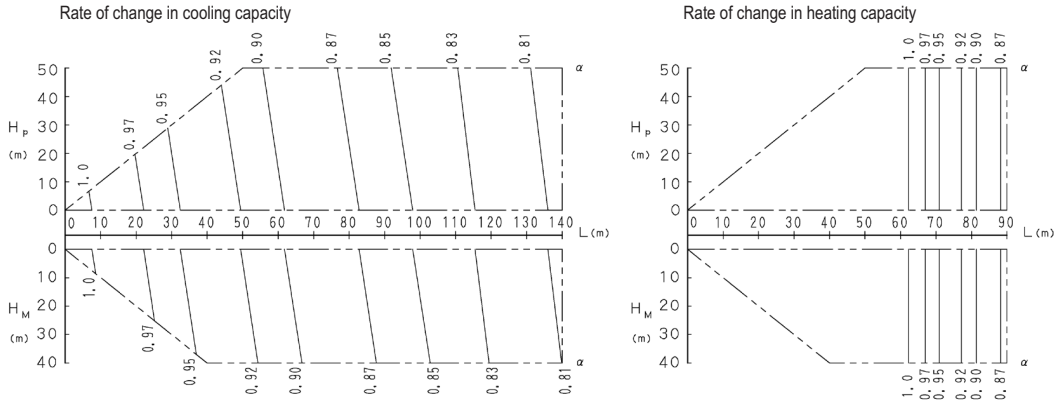

3D048283D

NOTES

- These figures illustrate the rate of change in capacity for a standard indoor unit system at maximum load (with the thermostat set to maximum) under standard conditions. Moreover, under partial load conditions, there is only a minor deviation from the rate of change in capacity shown in the above figures.
- With this outside unit, evaporating pressure constant control when cooling and condensing pressure constant control when heating is carried out.
- Method of calculating A/C (cooling/heating) capacity:
The maximum A/C capacity of the system will be either the total A/C capacity of the indoor units obtained from capacity characteristic table or the maximum A/C capacity of outside units as mentioned below, whichever smaller.

Calculating A/C capacity of outside units

- Condition: Indoor unit combination ratio does not exceed 100%.

$$\text{Maximum A/C capacity of outside units} = \frac{\text{A/C capacity of outside units obtained from capacity characteristic table at the 100\% combination}}{\text{Capacity change rate due to piping length to the farthest indoor unit}}$$

- Condition: Indoor unit combination ratio exceeds 100%.

$$\text{Maximum A/C capacity of outside units} = \frac{\text{A/C capacity of outside units obtained from capacity characteristic table at the combination}}{\text{Capacity change rate due to piping length to the farthest indoor unit}}$$

- When overall equivalent pipe length is 80m or more, the diameter of the main liquid pipes (outside unit-branch sections) must be increased.
Diameter of above case

Model	Liquid pipe
RWEYQ10P	Ø12.7
RWEYQ20P	Ø19.1

- Read cooling/heating capacity rate of change in the above figures based on the following equivalent length

$$\text{Overall equivalent length} = (\text{equivalent length to main pipe}) \times \text{Correction factor} + (\text{Equivalent length after branching})$$

Choose a correction factor from the following table.

- When cooling capacity is calculated: gas pipe size
- When heating capacity is calculated: liquid pipe size.

Rate of change (object piping)	Correction factor	
	Standard size	Size increase
Cooling (gas pipe)	1.0	—
Heating (liquid pipe)	1.0	0.5

(Example) RWEYQ10PY1

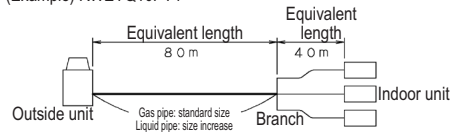

In the above case

(Cooling) Overall equivalent length = 80m x 1.0 + 40m = 120m

(Heating) Overall equivalent length = 80m x 0.5 + 40m = 80m

The correction factor in:

cooling capacity when Hp = 0m is thus approximately 0.82

heating capacity when Hp = 0m is thus approximately 0.90

- Explanation of symbols

H_p: Level difference (m) between indoor and outside units where indoor unit in inferior position

H_v: Level difference (m) between indoor and outside units where indoor unit in superior position

L: Equivalent pipe length (m)

α: Capacity correction factor

Diameter of pipes

Model	Liquid pipe
RWEYQ10P	Ø9.5
RWEYQ20P	Ø15.9

6 Capacity correction factor

RWEYQ16,18,24,26,28,30P

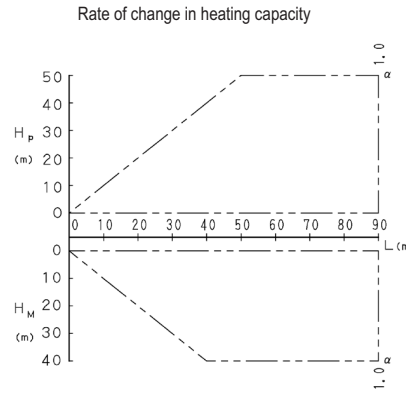
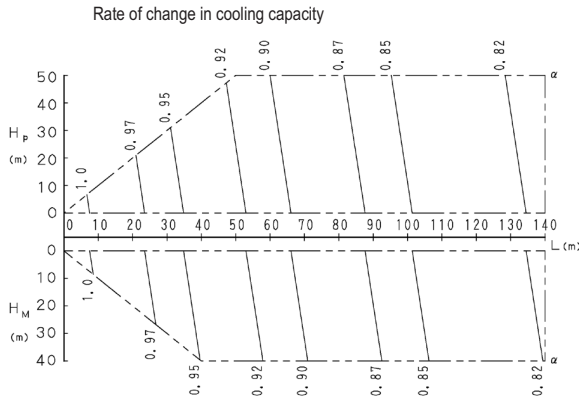

3D048284D

NOTES

- These figures illustrate the rate of change in capacity for a standard indoor unit system at maximum load (with the thermostat set to maximum) under standard conditions. Moreover, under partial load conditions, there is only a minor deviation from the rate of change in capacity shown in the above figures.
- With this outside unit, evaporating pressure constant control when cooling and condensing pressure constant control when heating is carried out.
- Method of calculating A/C (cooling/heating) capacity:
The maximum A/C capacity of the system will be either the total A/C capacity of the indoor units obtained from capacity characteristic table or the maximum A/C capacity of outside units as mentioned below, whichever smaller.

Calculating A/C capacity of outside units

- Condition: Indoor unit combination ratio does not exceed 100%.

$$\text{Maximum A/C capacity of outside units} = \text{A/C capacity of outside units obtained from capacity characteristic table at the 100\% combination} \times \text{Capacity change rate due to piping length to the farthest indoor unit}$$

- Condition: Indoor unit combination ratio exceeds 100%.

$$\text{Maximum A/C capacity of outside units} = \text{A/C capacity of outside units obtained from capacity characteristic table at the combination} \times \text{Capacity change rate due to piping length to the farthest indoor unit}$$

- When overall equivalent pipe length is 80m or more, the diameter of the main liquid pipes (outside unit-branch sections) must be increased.
Diameter of above case

Model	Liquid pipe
RWEYQ16P	Ø15.9
RWEYQ18,24P	Ø19.1
RWEYQ26,28,30P	Ø22.2

- Read cooling/heating capacity rate of change in the above figures based on the following equivalent length

$$\text{Overall equivalent length} = (\text{equivalent length to main pipe}) \times \text{Correction factor} + (\text{Equivalent length after branching})$$

Choose a correction factor from the following table.

- When cooling capacity is calculated: gas pipe size
- When heating capacity is calculated: liquid pipe size.

Rate of change (object piping)	Correction factor	
	Standard size	Size increase
Cooling (gas pipe)	1.0	—
Heating (liquid pipe)	1.0	0.5

(Example) RWEYQ30PY1

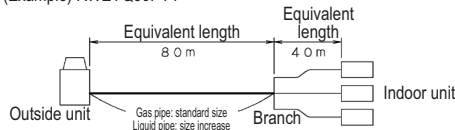

In the above case

(Cooling) Overall equivalent length = 80m x 1.0 + 40m = 120m

(Heating) Overall equivalent length = 80m x 0.5 + 40m = 80m

The correction factor is:

cooling capacity when H_p = 0m is thus approximately 0.83

heating capacity when H_p = 0m is thus approximately 1.0

- Explanation of symbols

H_p: Level difference (m) between indoor and outside units where indoor unit in inferior position

H_M: Level difference (m) between indoor and outside units where indoor unit in superior position

L: Equivalent pipe length (m)

α: Capacity correction factor

Diameter of pipes

Model	Liquid pipe
RWEYQ16P	Ø12.7
RWEYQ18,24P	Ø15.9
RWEYQ26,28,30P	Ø19.1

7 Refnet pipe systems

1
7

	LIQUID SIDE JUNCTION	DISCHARGE GAS SIDE JUNCTION	SUCTION GAS SIDE JUNCTION	
KHRP22M64T8		/		
KHRP22M75T8				
KHRQ22M20T8				
KHRQ22M29T9				
KHRQ22M64T8				
KHRQ22M75T8				
KHRP23M3T8				
KHRP23M64T8				
KFRP23M75T8				
KHRQ23M20T8				
KHRQ23M29T9				
KHRQ23M64T8				
KHRQ23M75T8				
KHRQ68T7				

CLOSED PIPES		
(A)	(B)	(C)
(D)	(E)	

1TW25799-4D

7 Refnet pipe systems

	LIQUID SIDE JUNCTION	DISCHARGE GAS SIDE JUNCTION	SUCTION GAS SIDE JUNCTION
KHRQ22M29H8			
KHRQ22M64H8			
KHRQ22M75H8			
KHRQ23M29H8			
KHRQ23M64H8			
KHRQ23M75H8			

KFRQ250H8			
KHRP127H8			
KHRQ127H8			
KHRQ58H7			

REDUCERS - EXPANDERS	1	2	3

1TW25799-4D

7 Refnet pipe systems

BHFP22-26MA56

Liquid-side joint

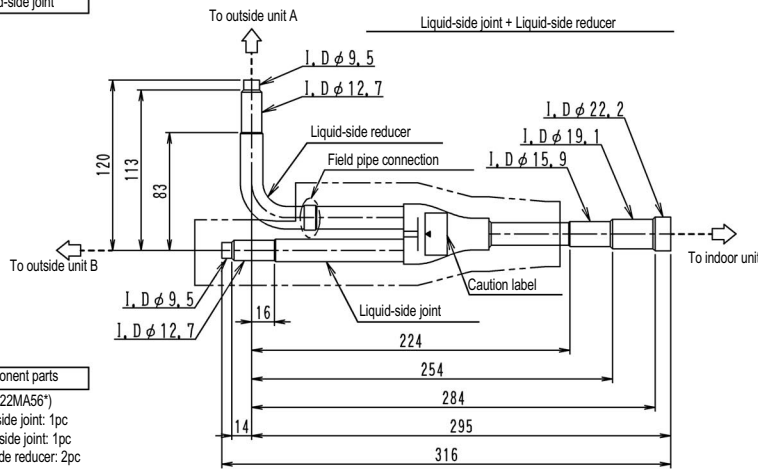

Component parts

- (BHFP22MA56*)
- Gas side joint: 1pc
- Liquid side joint: 1pc
- Gas-side reducer: 2pc
- Gas-side accessory pipe: 2pc
- Liquid-side reducer: 1pc
- Thermal insulation: 2pc
- Insulating tube for gas pipe: 2pc
- Insulating tube for liquid pipe: 1pc
- Installation manual
- * Refer to outside drawing of for the component parts in case of BHFP26MA56.

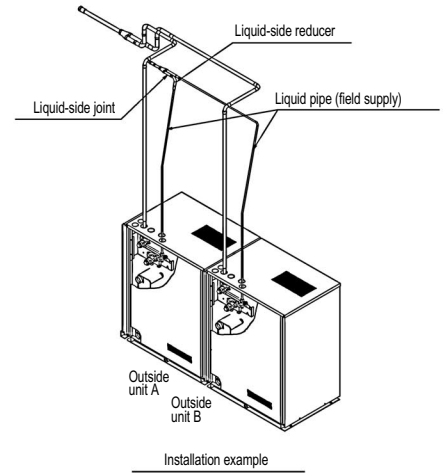
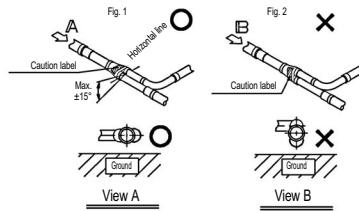

3D049158

NOTES

- 1 ---- in figure shows the (field supply) connecting piping.
- 2 See "Installation Manual" or "Engineering Data" for details on the necessary connecting piping.
- 3 Observe the following limitation when you set up this kit.
 - Install the joint horizontally so that the caution label attached to joint comes to the top. Do not tilt the joint more than $\pm 15^\circ$. (see Fig. 1). In addition, do not install the joint vertically. (See fig. 2)

7 Refnet pipe systems

BHFP22-26MA56

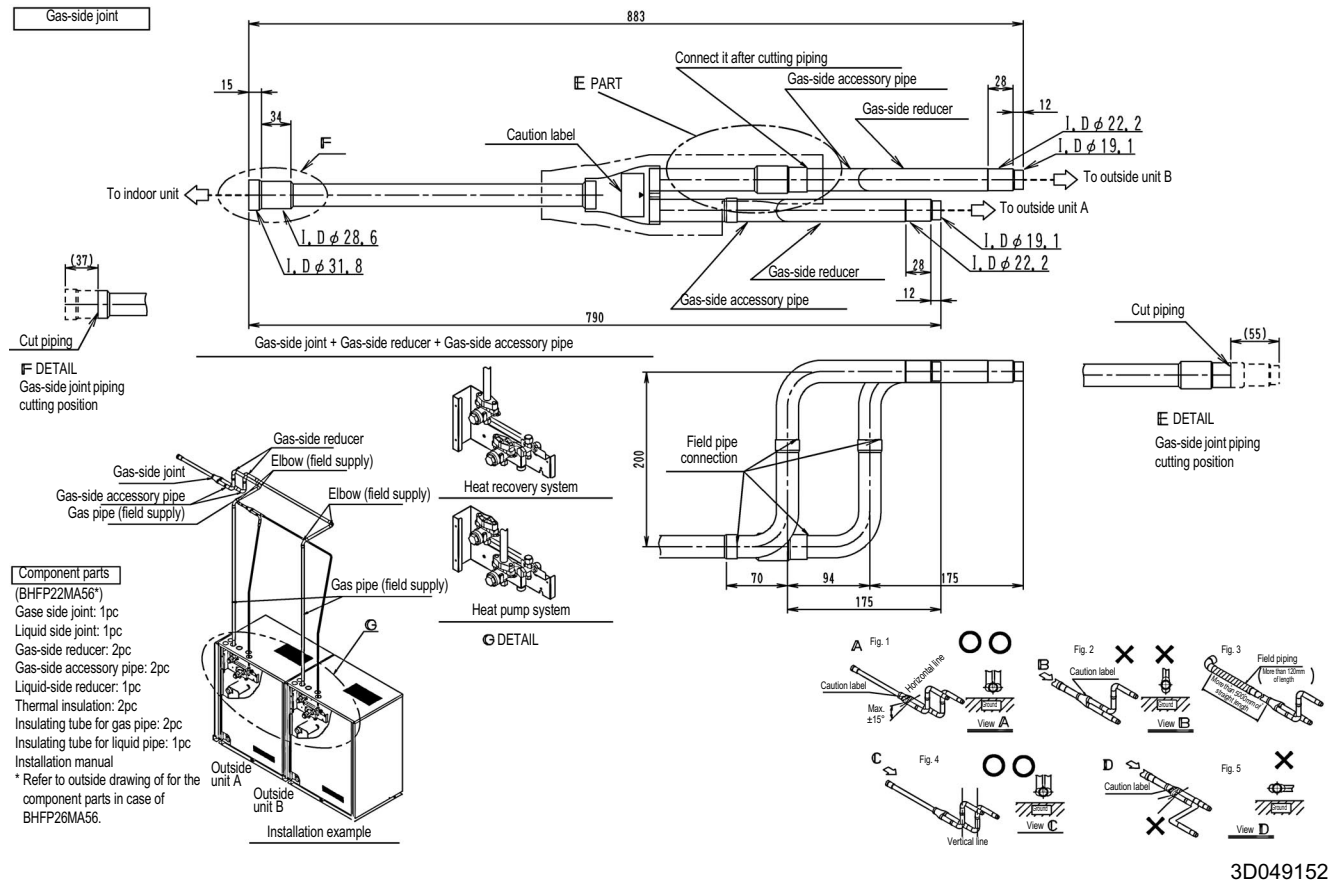

3D049152

NOTES

- 1 --- in figure shows the (field supply) connecting piping.
- 2 See "Installation Manual" or "Engineering Data" for details on the necessary connecting piping.
- 3 Observe the following limitation when you set up this kit.
 - Install the joint horizontally so that the caution label attached to joint comes to the top.
Do not tilt the joint more than $\pm 15^\circ$. (See Fig. 1). In addition, do not install the joint vertically. (See fig. 2)
 - Make sure the piping up to the joint is straight for more than 500mm. Do not bend the field piping within this range.
If a straight field piping more than 120mm is connected, more than 500mm of straight section can be ensured. (See Fig. 3)
 - Improper installation may lead to malfunction of the outside unit.
 - Set up the part of L bend of the gas piping to be vertical and upward after it diverges. (See Fig. 1,4)
 - In addition, do not install it as shown in Fig. 5.

1
7

7 Refnet pipe systems

BHFP22-26MA56

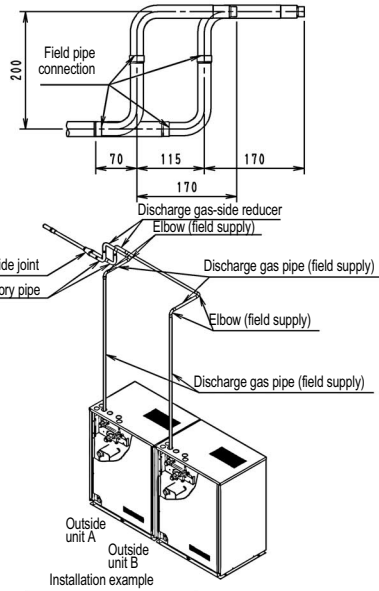
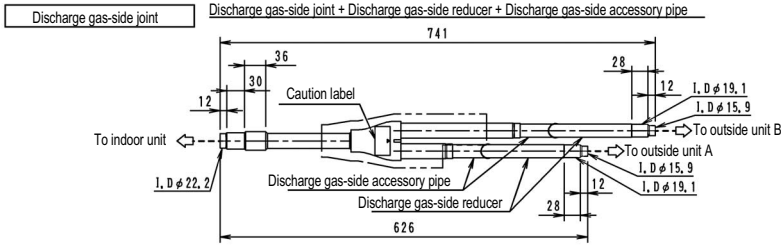

- Component parts**
 (BHFP22MA56)
 Suction gas-side joint: 1pc
 Discharge gas-side joint: 1pc
 Liquid side joint: 1pc
 Suction gas-side accessory pipe: 2pc
 Discharge gas-side accessory pipe: 2pc
 Suction gas-side reducer: 2pc
 Discharge gas-side reducer: 2pc
 Liquid-side reducer: 1pc
 Thermal insulation: 2pc
 Insulating tube for gas pipe: 4pc
 Insulating tube for liquid pipe: 1pc
 Installation manual

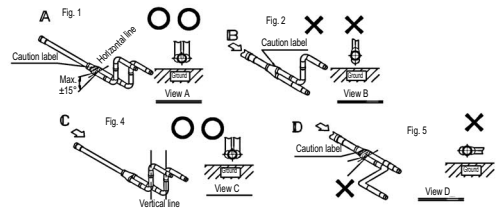

3D049206

NOTES

- in figure shows the (field supply) connecting piping.
- See "Installation Manual" or "Engineering Data" for details on the necessary connecting piping.
- Observe the following limitation when you set up this kit.
 - Install the joint horizontally so that the caution label attached to joint comes to the top. Do not tilt the joint more than $\pm 15^\circ$. (see Fig. 1). In addition, do not install the joint vertically. (See fig. 2)
 - Improper installation may lead to malfunction of the outside unit.
 - Set up the part of L bend of the gas piping to be vertical and upward after it diverges. (See Fig. 1,3)
 - In addition, do not install it as shown in Fig. 4.

7 Refnet pipe systems

BHFP22-26MA84

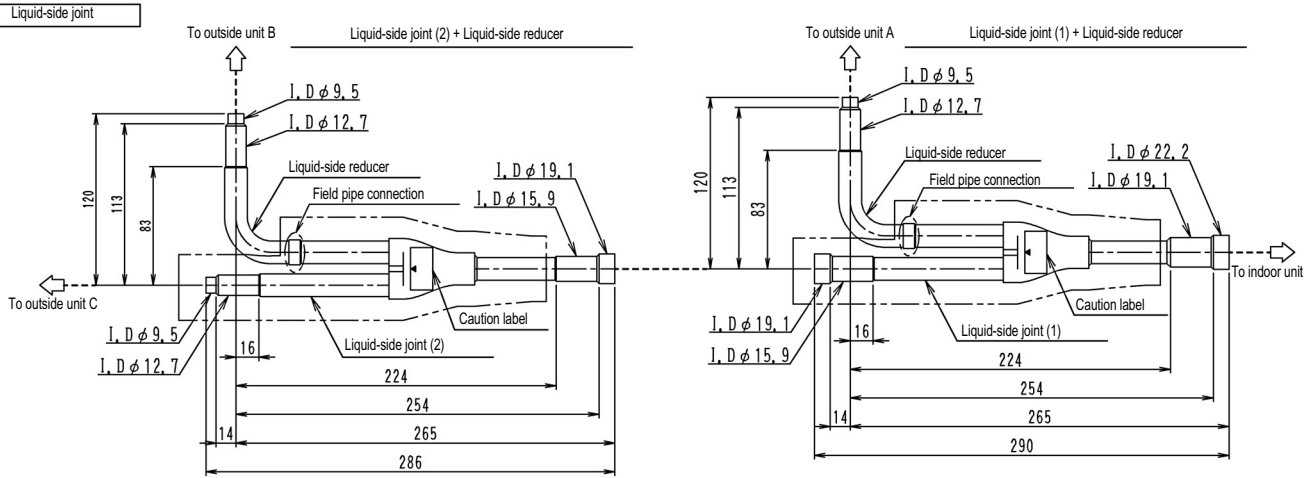

Component parts

(BHFP22MA84*)

- Gas side joint: 2pc
- Liquid side joint (1): 1pc
- Liquid side joint (2): 1pc
- Gas-side accessory pipe: 3pc
- Gas-side reducer (1): 3pc
- Gas-side reducer (2): 1pc
- Liquid-side reducer: 2pc
- Thermal insulation: 4pc
- Insulating tube for gas pipe: 3pc
- Insulating tube for liquid pipe: 2pc
- Installation manual

* Refer to outside drawing for the component parts in case of BHFP26MA56.

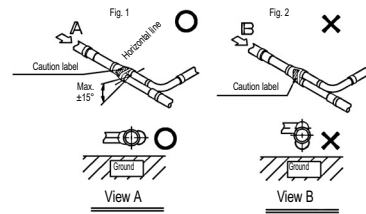
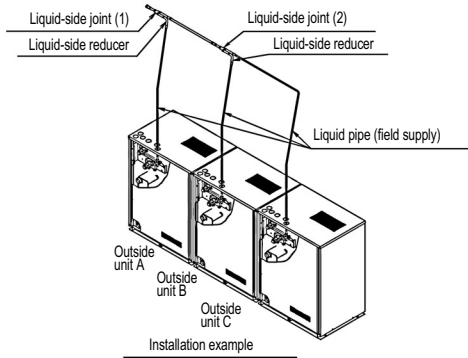

3D049157

NOTES

- 1 ---- in figure shows the (field supply) connecting piping.
- 2 See "Installation Manual" or "Engineering Data" for details on the necessary connecting piping.
- 3 Observe the following limitation when you set up this kit.
 - Install the joint horizontally so that the caution label attached to joint comes to the top. Do not tilt the joint more than $\pm 15^\circ$. (see Fig. 1). In addition, do not install the joint vertically. (See fig. 2)

1
7

7 Refnet pipe systems

BHFP22-26MA84

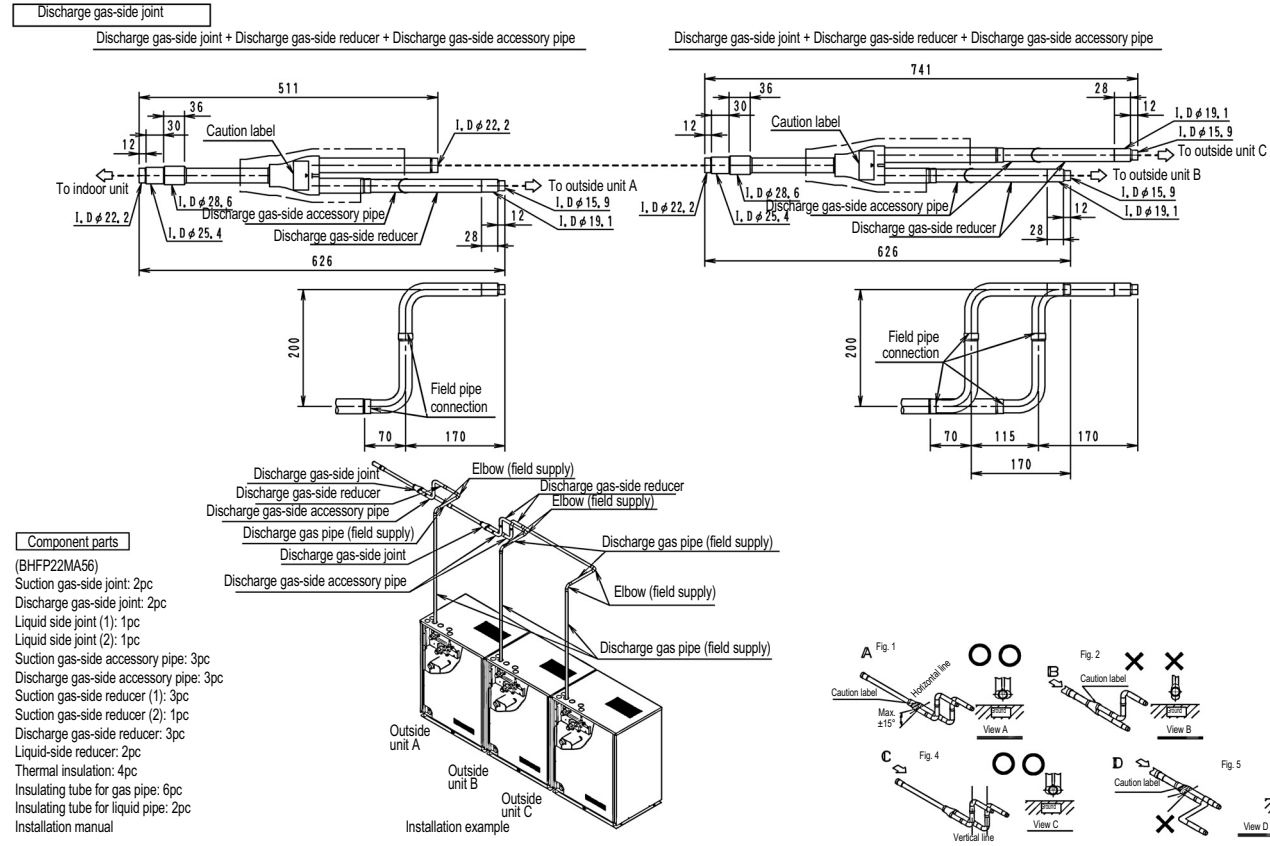

3D049205

NOTES

- 1 ---- in figure shows the (field supply) connecting piping.
- 2 See "Installation Manual" or "Engineering Data" for details on the necessary connecting piping.
- 3 Observe the following limitation when you set up this kit.
 - Install the joint horizontally so that the caution label attached to joint comes to the top. Do not tilt the joint more than $\pm 15^\circ$. (See Fig. 1). In addition, do not install the joint vertically. (See Fig. 2)
 - Improper installation may lead to malfunction of the outside unit.
 - Set up the part of L bend of the gas piping to be vertical and upward after it diverges. (See Fig. 1,3)
 - In addition, do not install it as shown in Fig. 4.

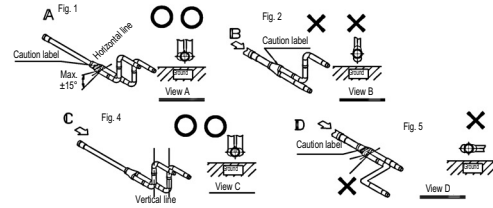

1
7

8 Refrigerant pipe selection

8 - 1 Standard series

RWEYQ-P

System	Liquid pipe
RWEYQ8_10PY1	φ9.5 → φ12.7
RWEYQ16PY1	φ12.7 → φ15.9
RWEYQ18 ~ 24PY1	φ15.9 → φ19.1
RWEYQ26 ~ 30PY1	φ19.1 → φ22.2

Note 1. When the equivalent pipe length between outside and indoor units is 80m or more, the size of main pipes on the liquid side (refer to figure 21) must be increased according to the right table.
(Never increase suction gas pipe and HP/LP gas pipe.)

(Refer to figure 21)

1. Outside unit
2. Main pipes
3. Increase only liquid pipe size
4. First refrigerant branch kit
5. Indoor unit

Note 2. Allowable length after the first refrigerant branch kit to indoor units is 40m or less, however it can be extended up to 90m if all the following conditions are satisfied. (In case of "Branch with REFNET joint")

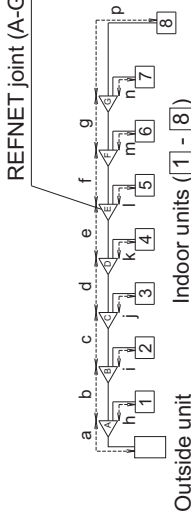
Required Conditions	Example Drawings
1. It is necessary to increase the liquid and suction gas pipe size between the first branch kit and the final branch kit. (Reducers must be procured on site) However, the pipes that are same pipe size with main pipe must not be increased.	[8] $b + c + d + e + f + g + p \leq 90$ m increase the liquid and suction gas pipe size of b, c, d, e, f, g Increase the liquid and suction gas pipe size as follows $\phi 9.5 \rightarrow \phi 12.7$ $\phi 15.9 \rightarrow \phi 19.1$ $\phi 22.2 \rightarrow \phi 25.4^*$ $\phi 34.9 \rightarrow \phi 38.1^*$ $\phi 12.7 \rightarrow \phi 15.9$ $\phi 19.1 \rightarrow \phi 22.2$ $\phi 28.6 \rightarrow \phi 31.8^*$
2. For calculation of Total extension length, the actual length of above pipes must be doubled. (except main pipe and the pipes that are not increased)	REFNET joint (A-G)  Indoor units ([1] - [8])
3. Indoor unit to the nearest branch kit ≤ 40 m 4. The difference between [Outside unit to the farthest indoor unit] and [Outside unit to the nearest indoor unit] ≤ 40 m	

*If available on the site, use this size. Otherwise it can not be increased.

This table is about a heat recovery system (3-piping: suction gas, HP/LP gas and liquid pipes).
 In a case of heat pump system (2-piping: gas and liquid pipes), select the pipe size from suction gas pipe for gas pipes and from liquid gas pipe for liquid pipes. And BS unit is not required.

3P153897-8L

8 Refrigerant pipe selection

8 - 1 Standard series

RWEYQ-P

System	Liquid pipe
RWEYQ8~10PY1	φ9.5 → φ12.7
RWEYQ16PY1	φ12.7 → φ15.9
RWEYQ18~24PY1	φ15.9 → φ19.1
RWEYQ26~30PY1	φ19.1 → φ22.2

Note 1. When the equivalent pipe length between outside and indoor units is 80m or more, the size of main pipes on the liquid side (refer to figure 21) must be increased according to the right table.
(Never increase suction gas pipe and HP/LP gas pipe.)

(Refer to figure 21)

1. Outside unit
2. Main pipes
3. Increase only liquid pipe size
4. First refrigerant branch kit
5. Indoor unit

Note 2. Allowable length after the first refrigerant branch kit to indoor units is 40m or less, however it can be extended up to 90m if all the following conditions are satisfied. (In case of "Branch with REFNET joint")

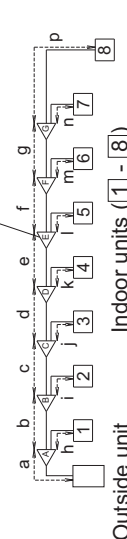
Required Conditions	Example Drawings
1. It is necessary to increase the liquid and suction gas pipe size between the first branch kit and the final branch kit. (Reducers must be procured on site) However, the pipes that are same pipe size with main pipe must not be increased.	<div style="display: flex; align-items: center;"> <div style="margin-right: 20px;"> <p>[8] $b + c + d + e + f + g + p \leq 90$ m</p> <p>increase the liquid and suction gas pipe size of b, c, d, e, f, g</p> </div>  </div>
2. For calculation of Total extension length, the actual length of above pipes must be doubled, (except main pipe and the pipes that are not increased)	<p>$a + b \times 2 + c \times 2 + d \times 2 + e \times 2 + f \times 2 + g \times 2 + h + i + j + k + l + m + n + p \leq 300$ m</p>
3. Indoor unit to the nearest branch kit ≤ 40 m	<p>$h, i, j, \dots, p \leq 40$ m</p>
4. The difference between [Outside unit to the farthest indoor unit] and [Outside unit to the nearest indoor unit] ≤ 40 m	<p>The farthest indoor unit [8] The nearest indoor unit [1] $(a + b + c + d + e + f + g + p) - (a + h) \leq 40$ m</p>

*If available on the site, use this size. Otherwise it can not be increased.

This table is about a heat recovery system (3-piping: suction gas, HP/LP gas and liquid pipes).
In a case of heat pump system (2-piping: gas and liquid pipes), select the pipe size from suction gas pipe for gas pipes and from liquid gas pipe for liquid pipes. And BS unit is not required.

3P153897-8L

8 Refrigerant pipe selection

8 - 2 Geothermal series

RWEYQ-PR

1
8

Example of connection

(Connection of 8 indoor units Heat pump system) (2-pipe)

• Piping between outside unit and BS unit
 — (Thick line): 3-pipe
 — (Thin line): 2-pipe

• Piping between BS unit and indoor unit,
 — (Thick line): 3-pipe
 — (Thin line): 2-pipe

Branch with REFRNET joint

Example 1

Example 2

Example 3

Branch with REFRNET joint and REFRNET header

Example 3

Branch with REFRNET header

Example 3

Pipe length between outside (a) and indoor units ≤ 120m
 (Example 1) unit [a] + b + c + d + e + s ≤ 120m
 Equivalent pipe length between outside and indoor units ≤ 140m (Note 1) (assume equivalent pipe length of REFRNET joint to be 1m, BSVQ100, 160 is 4 m and BSVQ250 is 6 m.)
 Total piping length from outside unit to all indoor units ≤ 300m
 Difference in height between outside and indoor units (H1) ≤ 50m (Max. 40m if the outside unit is below)
 Difference in height between indoor units (H2) ≤ 15m
 Difference in height between outside unit (main) and outside unit (sub) (H3) ≤ 2m

Additional piping limitations based on inlet water temperature in cooling refer to table; piping limitations based on inlet water temperature in cooling mode (brine concentration 40%)
 (Example 1) unit [a], b + c + d + e + s ≤ 40m
 (Example 2) unit [a], b + c + d + e + s ≤ 40m
 (Example 3) unit [a], b + c + d + e + s ≤ 40m

Refrigerant branch kit selection

Refrigerant branch kits can only be used with R410A.

Outside unit capacity type	Heat recovery system	Refrigerant branch kit name
RWEYQ8, 10 type	RTRCQ22M29T9	RTRCQ22M29T9
Indoor capacity index	Heat pump system	In case of 3-tube piping
		KHRQ22M20T
		KHRQ22M29T9
Indoor capacity index	Heat recovery system	In case of 2-tube piping
		KHRQ22M64T

• For REFRNET joints other than the first branch, select the proper branch kit model based on the total capacity index.

How to select REFRNET joint

When using REFRNET joints at the first branch counted from the outside unit side, choose from the following table in accordance with the capacity of the outside unit.
 (Example 1: 2, 4, 8 REFRNET joints)

Indoor capacity index	Refrigerant branch kit name
< 200	KHRQ22M29H
200 ≤ X < 290	KHRQ22M29H
290 ≤ X < 640	KHRQ22M64H

Pipe size selection

Example of downstream indoor units

△ Caution
 The thickness of the pipes in this table shows the requirements of Japanese HP/PLP. In the U.S., ASME 2001, the thickness and material shall be selected in accordance with local code.

Capacity type of outside unit	Suction gas pipe	HP/PLP gas pipe	Liquid pipe
RWEYQ8	φ19.1 × 0.80	φ15.9 × 0.89	φ 9.5 × 0.80
RWEYQ10	φ22.2 × 0.80	φ19.1 × 0.80	φ 9.5 × 0.80

(Unit: mm)

Example 1) In case of REFRNET Joint ◀, indoor units of [a] + [b] + [c] + [d]
 Piping between outside unit and refrigerant branch kit (part A)
 Piping between outside branch and outside unit (part C)
 • Match to the size of connection piping of outside unit

Indoor capacity index	Suction gas pipe	HP/PLP gas pipe	Liquid pipe
< 150	φ15.9 × 0.89	φ12.7 × 0.80	φ 9.5 × 0.80
150 ≤ X < 200	φ19.1 × 0.80	φ15.9 × 0.89	φ 9.5 × 0.80
200 ≤ X < 290	φ22.2 × 0.80	φ19.1 × 0.80	φ12.7 × 0.80
290 ≤ X < 640	φ28.6 × 0.89	φ19.1 × 0.80	φ12.7 × 0.80

(Unit: mm)

Example 2) In case of REFRNET Joint ◀, indoor units of [a] + [b] + [c] + [d] + [e] + [f]
 Piping between refrigerant branch kit and refrigerant branch kit (BS unit)
 Piping between BS unit and refrigerant branch kit (BS unit)
 • Select one from the table below according to the total capacity of indoor units to be connected to downstream.
 • In case of 2-tube piping between refrigerant branching kit (BS unit) and refrigerant branching kit, select the size of suction gas piping.
 • The size of connection piping should not exceed the refrigerant piping size selected under the generic term of the system.

Indoor capacity index	Suction gas pipe	HP/PLP gas pipe	Liquid pipe
< 200	φ15.9 × 0.89	φ12.7 × 0.80	φ 9.5 × 0.80
200 ≤ X < 290	φ19.1 × 0.80	φ15.9 × 0.89	φ 9.5 × 0.80
290 ≤ X < 640	φ22.2 × 0.80	φ19.1 × 0.80	φ12.7 × 0.80

(Unit: mm)

Example 3) In case of REFRNET Header, indoor units of [a] + [b] + [c] + [d] + [e] + [f] + [g]
 Piping between BS unit (refrigerant branch kit) and indoor unit.
 • Match to the size of the connection piping on the indoor unit.
 • Indoor unit connection piping size

Indoor capacity type	Gas pipe	Liquid pipe
20, 25, 32, 40, 50 type	φ12.7 × 0.80	φ6.4 × 0.80
63, 80, 100, 125 type	φ15.9 × 0.89	φ9.5 × 0.80
200 type	φ19.1 × 0.80	φ9.5 × 0.80
250 type	φ22.2 × 0.80	φ9.5 × 0.80

How to calculate the additional refrigerant to be charged

Additional refrigerant to be charged R (kg)
 (R should be rounded off in units of 0.1kg.)

R = (Total length in liquid) × 0.37 (kg/m) + (Total length in liquid) × 0.29 (kg/m) + (Total length in liquid) × 0.13 (kg/m) + (Total length in liquid) × 0.13 (kg/m) + (Total length in liquid) × 0.13 (kg/m) + (Total length in liquid) × 0.13 (kg/m)

System name: RWEYQ8-10
 Heat pump system: 3 kg
 Heat recovery system: 4 kg

3P153897-8LR

8 Refrigerant pipe selection

8 - 2 Geothermal series

RWEYQ-PR

System	Liquid pipe
RWEYQ8, 10PR	φ9.5 → φ12.7

Note 1. When the equivalent pipe length between outside and indoor units is 80m or more, the size of main pipes on the liquid side (refer to figure 21) must be increased according to the right table.
(Never increase suction gas pipe and HP/LP gas pipe.)

(Refer to figure 21)

1. Outside unit
2. Main pipes
3. Increase only liquid pipe size
4. First refrigerant branch kit
5. Indoor unit

Note 2. Allowable length after the first refrigerant branch kit to indoor units is 40m or less, however it can be extended up to 90m if all the following conditions are satisfied. (In case of "Branch with REFNET joint")

Required Conditions	Example Drawings		
1. It is necessary to increase the liquid and suction gas pipe size between the first branch kit and the final branch kit. (Reducers must be procured on site) However, the pipes that are same pipe size with main pipe must not be increased.	<table border="1"> <tr> <td> $b + c + d + e + f + g + p \leq 90 \text{ m}$ increase the liquid and suction gas pipe size of b, c, d, e, f, g </td> <td> Increase the liquid and suction gas pipe size as follows $\phi 9.5 \rightarrow \phi 12.7$ $\phi 15.9 \rightarrow \phi 19.1$ $\phi 22.2 \rightarrow \phi 25.4^*$ $\phi 34.9 \rightarrow \phi 38.1^*$ $\phi 12.7 \rightarrow \phi 15.9$ $\phi 19.1 \rightarrow \phi 22.2$ $\phi 28.6 \rightarrow \phi 31.8^*$ </td> </tr> </table>	$b + c + d + e + f + g + p \leq 90 \text{ m}$ increase the liquid and suction gas pipe size of b, c, d, e, f, g	Increase the liquid and suction gas pipe size as follows $\phi 9.5 \rightarrow \phi 12.7$ $\phi 15.9 \rightarrow \phi 19.1$ $\phi 22.2 \rightarrow \phi 25.4^*$ $\phi 34.9 \rightarrow \phi 38.1^*$ $\phi 12.7 \rightarrow \phi 15.9$ $\phi 19.1 \rightarrow \phi 22.2$ $\phi 28.6 \rightarrow \phi 31.8^*$
$b + c + d + e + f + g + p \leq 90 \text{ m}$ increase the liquid and suction gas pipe size of b, c, d, e, f, g	Increase the liquid and suction gas pipe size as follows $\phi 9.5 \rightarrow \phi 12.7$ $\phi 15.9 \rightarrow \phi 19.1$ $\phi 22.2 \rightarrow \phi 25.4^*$ $\phi 34.9 \rightarrow \phi 38.1^*$ $\phi 12.7 \rightarrow \phi 15.9$ $\phi 19.1 \rightarrow \phi 22.2$ $\phi 28.6 \rightarrow \phi 31.8^*$		
2. For calculation of Total extension length, the actual length of above pipes must be doubled. (except main pipe and the pipes that are not increased)			
3. Indoor unit to the nearest branch kit $\leq 40 \text{ m}$			
4. The difference between [Outside unit to the farthest indoor unit] and [Outside unit to the nearest indoor unit] $\leq 40 \text{ m}$	$a + b \times 2 + c \times 2 + d \times 2 + e \times 2 + f \times 2 + g \times 2 + h + i + j + k + l + m + n + p \leq 300 \text{ m}$ $h, i, j, \dots, p \leq 40 \text{ m}$ The farthest indoor unit [8] The nearest indoor unit [1] $(a + b + c + d + e + f + g + p) - (a + h) \leq 40 \text{ m}$		

*If available on the site, use this size. Otherwise it can not be increased.

This table is about a heat recovery system (3-piping: suction gas, HP/LP gas and liquid pipes).
In a case of heat pump system (2-piping: gas and liquid pipes), select the pipe size from suction gas pipe for liquid gas pipe and from liquid gas pipe for liquid pipes. And BS unit is not required.

3P153897-8LR

9 Typical VRV®-WIII installations

9 - 1 Example Installation

Typical Installation

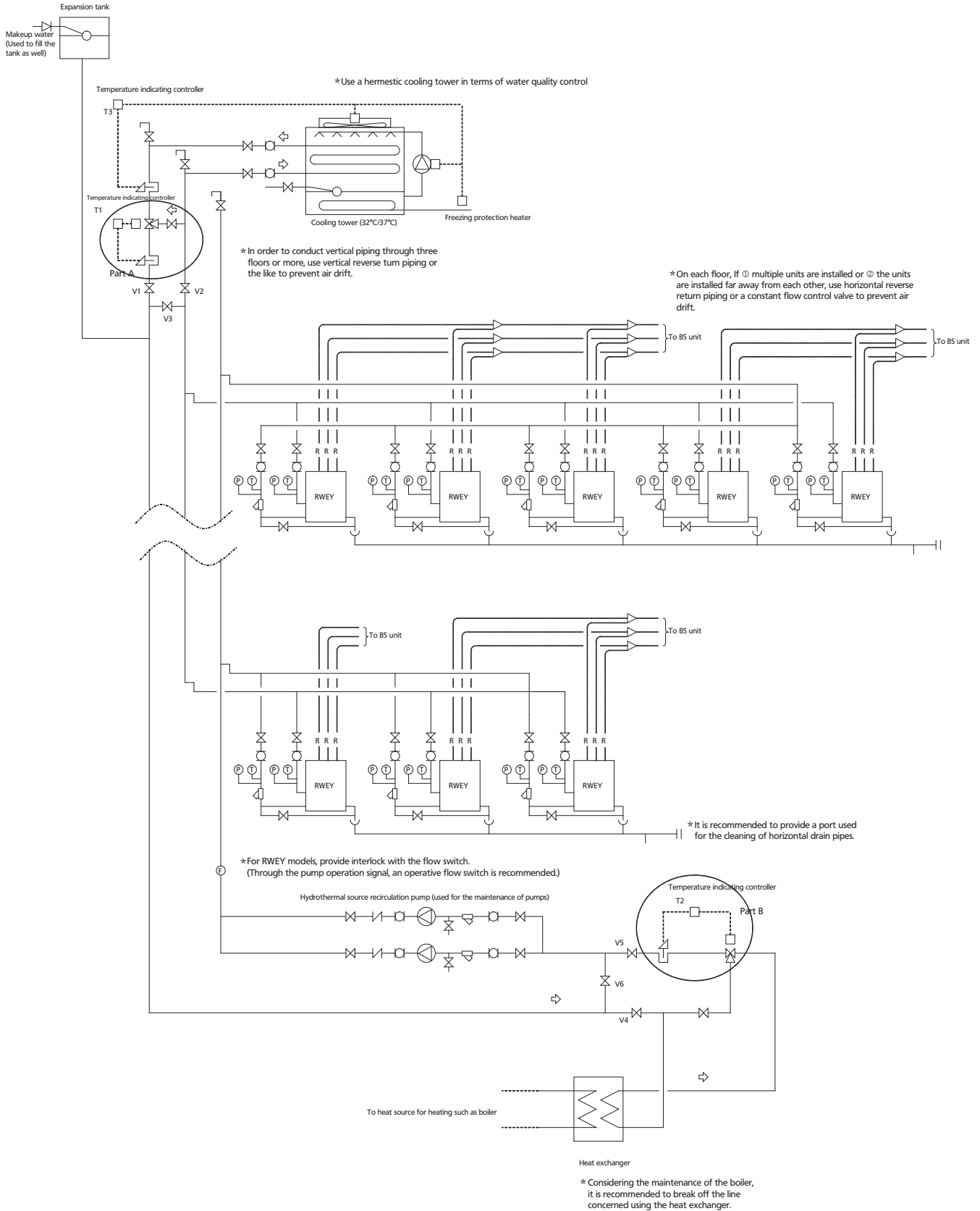

1
9

9 Typical VRV®-WIII installations

9 - 1 Example Installation

Note:
Please be noted that this Schematic Diagram is absolutely for reference only.
Practically, construction methods may vary with projects. Therefore, consult with the architect office for the design and construction of the system.

The following section shows precautions for the design of systems, which should be thoroughly observed.

- Temperature**
The operating range of hydrothermal cooling/heating free VRV® (RWEY) is 10°C to 45°C.
Keep the water temperature in the system within the said range through the ON/OFF operation of 2-way control valve, three-way control valve, cooling tower, or boiler.
- Water quality**
The hydrothermal cooling/heating free VRV® (RWEY) requires quality stability of water to be used.
Be sure to install the hermetic cooling water or, in order to install the open type cooling water, install the heat exchanger to break off the line concerned.
- Freezing**
Freezing protection should be provided for the cooling tower water during wintertime.
Take some sort of measures shown below so that water on the primary and secondary side of the cooling water will not freeze up during wintertime.
Typical measure: If the water temperature drops,
Start the pump to recirculate water.
Provide freezing protection using freezing protection heater.
Provide water temperature drop protection through the forced startup of the boiler.
Drain water from the cooling tower.
Particularly, if the unit should stop for an extended period of time, it may freeze up. Consequently, attention should be paid for this point.
- Air drift**
Provide constant amount of feed water through the installation of reverse return piping system and constant flow control valve.

Typical modification to Part A (Three-way valve → Two-way valve)

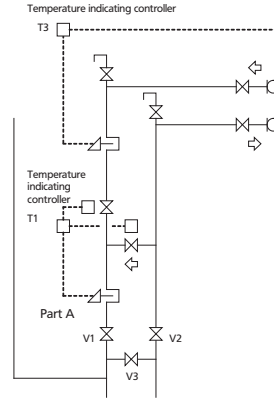

Typical modification to Part B (Three-way valve → Two-way valve)

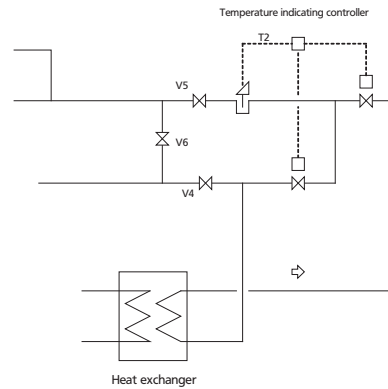

	Pump
	Temperature controller
	Three-way valve (mixed type)
	Y strainer
	Flexible joint
	Pressure gauge
	Thermometer
	Flow switch

Typical set values (reference values)

Operation mode	Cooling (mainly for cooling)	Heating (mainly for heating)	In-between seasons (cooling/heating combination)	
T1 set value	15°C		25°C	
T2 set value		40°C	20°C	
T3 set value	33°C, 31°C		33°C, 31°C	
Open/Closed of valve	V1	○	×	○
	V2	○	×	○
	V3	×	○	×
	V4	×	○	○
	V5	×	○	○
	V6	○	×	×

T1 Control

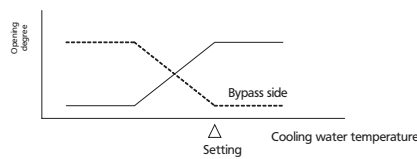

T2 control

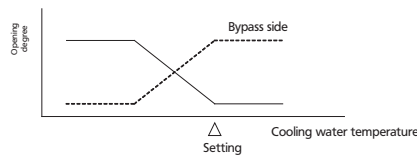

T3 control

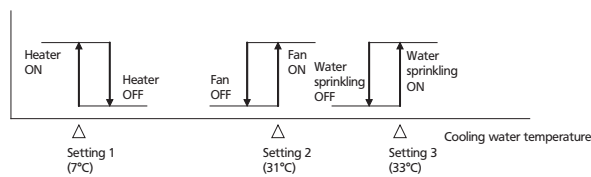

*If freezing is expected to occur, install the freezing protection heater or drain water from the water sprinkling side.
(If water is drained from the water sprinkling side, pay attention so that loads will never be applied to cooling mainly.)

9 Typical VRV®-WIII installations

9 - 2 Example Installation

(Use of open type cooling tower for low ambient climates)

Typical Installation (Installed in cold district, with open type cooling tower used)

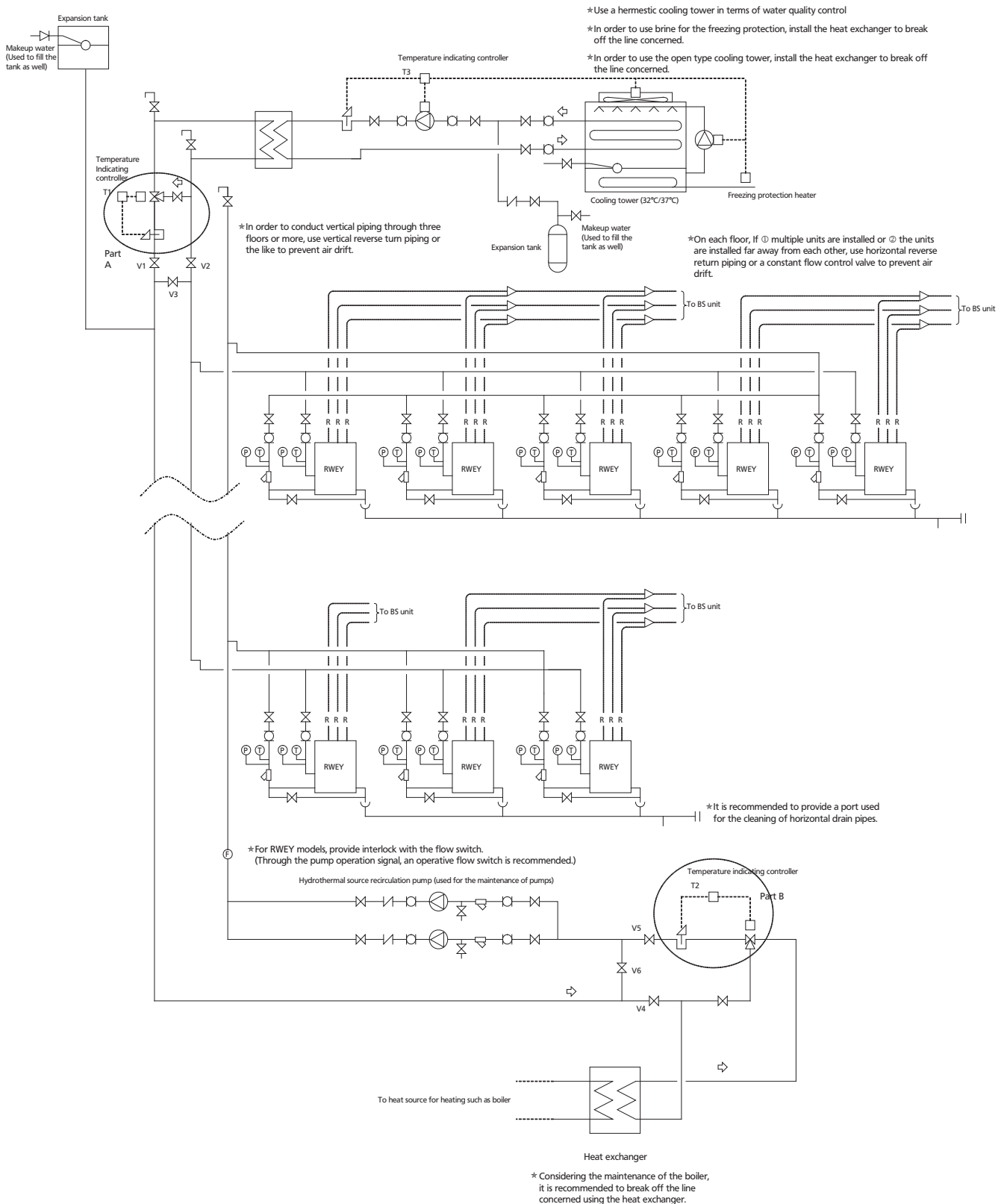

1
9

9 Typical VRV®-WIII installations

9 - 2 Example Installation

(Use of open type cooling tower for low ambient climates)

Note:
Please be noted that this Schematic Diagram is absolutely for reference only.
Practically, construction methods may vary with projects. Therefore, consult with the architect office for the design and construction of the system.

The following section shows precautions for the design of systems, which should be thoroughly observed.

1. Temperature
The operating range of hydrothermal cooling/heating free VRV® (RWEY) is 10°C to 45°C.
Keep the water temperature in the system within the said range through the ON/OFF operation of 2-way control valve, three-way control valve, cooling tower, or boiler.
2. Water quality
The hydrothermal cooling/heating free VRV® (RWEY) requires quality stability of water to be used.
Be sure to install the hermetic cooling water or, in order to install the open type cooling water, install the heat exchanger to break off the line concerned.
3. Freezing
Freezing protection should be provided for the cooling tower water during wintertime.
Take some sort of measures shown below so that water on the primary and secondary side of the cooling tower will not freeze up during wintertime.
Typical measure: If the water temperature drops,
Start the pump to recirculate water.
Provide freezing protection using freezing protection heater.
Provide water temperature drop protection through the forced startup of the boiler.
Drain water from the cooling tower.
Particularly, if the unit should stop for an extended period of time, it may freeze up. Consequently, attention should be paid for this point.
4. Air drift
Provide constant amount of feed water through the installation of reverse return piping system and constant flow control valve.

Typical modification to Part A (Three-way valve → Two-way valve)

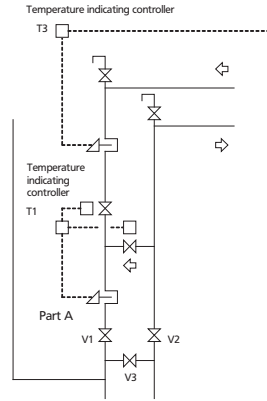

Typical modification to Part B (Three-way valve → Two-way valve)

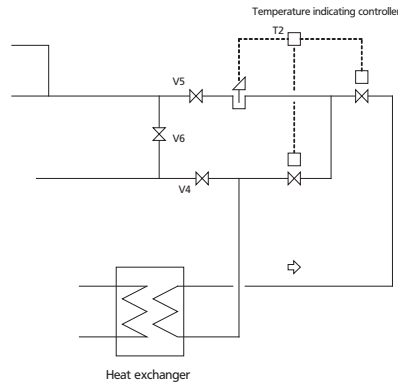

	Pump
	Temperature controller
	Three-way valve (mixed type)
	Y strainer
	Flexible joint
	Pressure gauge
	Thermometer
	Flow switch

Typical set values (reference values)

Operation mode	Cooling (mainly for cooling)	Heating (mainly for cooling)	In-between seasons (cooling/heating combination)
T1 set value	15°C		25°C
T2 set value		40°C	20°C
T3 set value	33°C, 31°C		33°C, 31°C
Open/Closed of valve			
Open: ○			
Closed: ×			
V1	○	×	○
V2	○	×	○
V3	×	○	×
V4	×	○	○
V5	×	○	○
V6	○	×	×

T1 Control

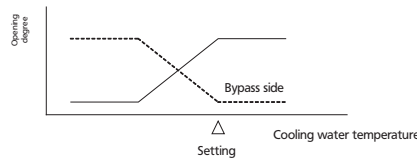

T2 Control

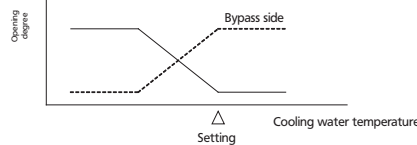

T3 Control

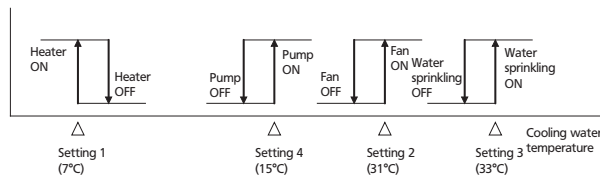

*If freezing is expected to occur, install the freezing protection heater or drain water from the water sprinkling side.
(If water is drained from the water sprinkling side, pay attention so that loads will never be applied to cooling mainly.)

9 Typical VRV®-WIII installations

9 - 3 Example Installation

(with part of central heating equipment used for this installation)

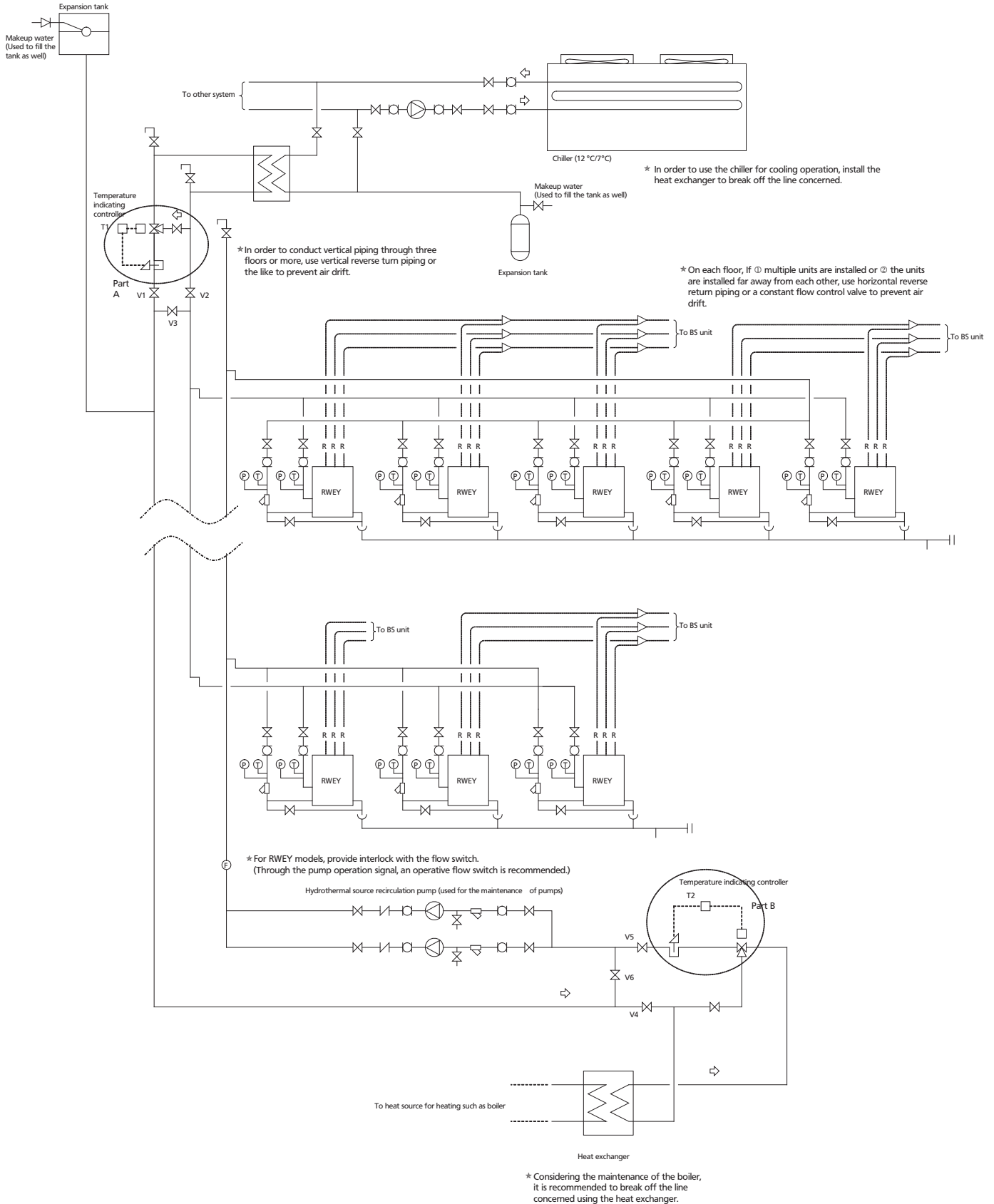

1
9

9 Typical VRV®-WIII installations

9 - 3 Example Installation

(with part of central heating equipment used for this installation)

Note:
Please be noted that this Schematic Diagram is absolutely for reference only.
Practically, construction methods may vary with projects. Therefore, consult with the architect office for the design and construction of the system.

The following section shows precautions for the design of systems, which should be thoroughly observed.

1. Temperature
The operating range of hydrothermal cooling/heating free VRV® (RWEY) is 10°C to 45°C.
Keep the water temperature in the system within the said range through the ON/OFF operation of 2-way control valve, three-way control valve, cooling tower, or boiler.
2. Water quality
The hydrothermal cooling/heating free VRV® (RWEY) requires quality stability of water to be used.
Be sure to install the hermetic cooling water or, in order to install the open type cooling water, install the heat exchanger to break off the line concerned.
3. Freezing
Freezing protection should be provided for the cooling tower water during wintertime.
Take some sort of measures shown below so that water on the primary and secondary side of the cooling water will not freeze up during wintertime.
Typical measure: If the water temperature drops,
Start the pump to recirculate water.
Provide freezing protection using freezing protection heater.
Provide water temperature drop protection through the forced startup of the boiler.
Drain water from the cooling tower.
Particularly, if the unit should stop for an extended period of time, it may freeze up. Consequently, attention should be paid for this point.
4. Air drift
Provide constant amount of feed water through the installation of reverse return piping system and constant flow control valve.

Typical modification to Part A (Three-way valve → Two-way valve)

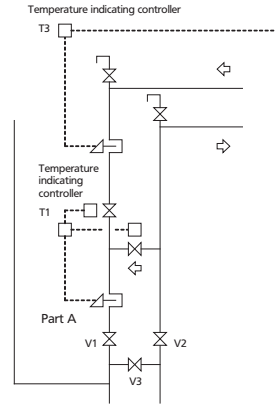

Typical modification to Part B (Three-way valve → Two-way valve)

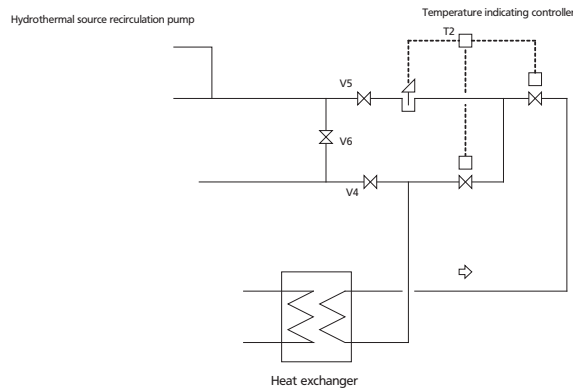

T1 Control

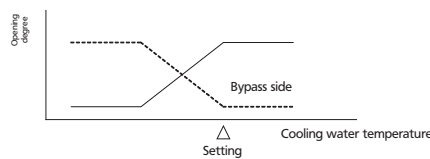

T2 Control

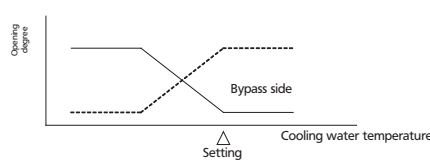

	Pump
	Temperature controller
	Three-way valve (mixed type)
	Y strainer
	Flexible joint
	Pressure gauge
	Thermometer
	Flow switch

Typical set values (reference values)

Operation mode	Cooling (mainly for cooling)	Heating (mainly for cooling)	In-between seasons (cooling/heating combination)
T1 set value	15°C		25°C
T2 set value		40°C	20°C
Open/Closed of valve	V1	○	×
	V2	○	×
	V3	×	○
Open: ○ Closed: ×	V4	×	○
	V5	×	○
	V6	○	×

9 Typical VRV®-WIII installations

9 - 4 Example Installation

(With heat recovery from multiple systems through water circuit)

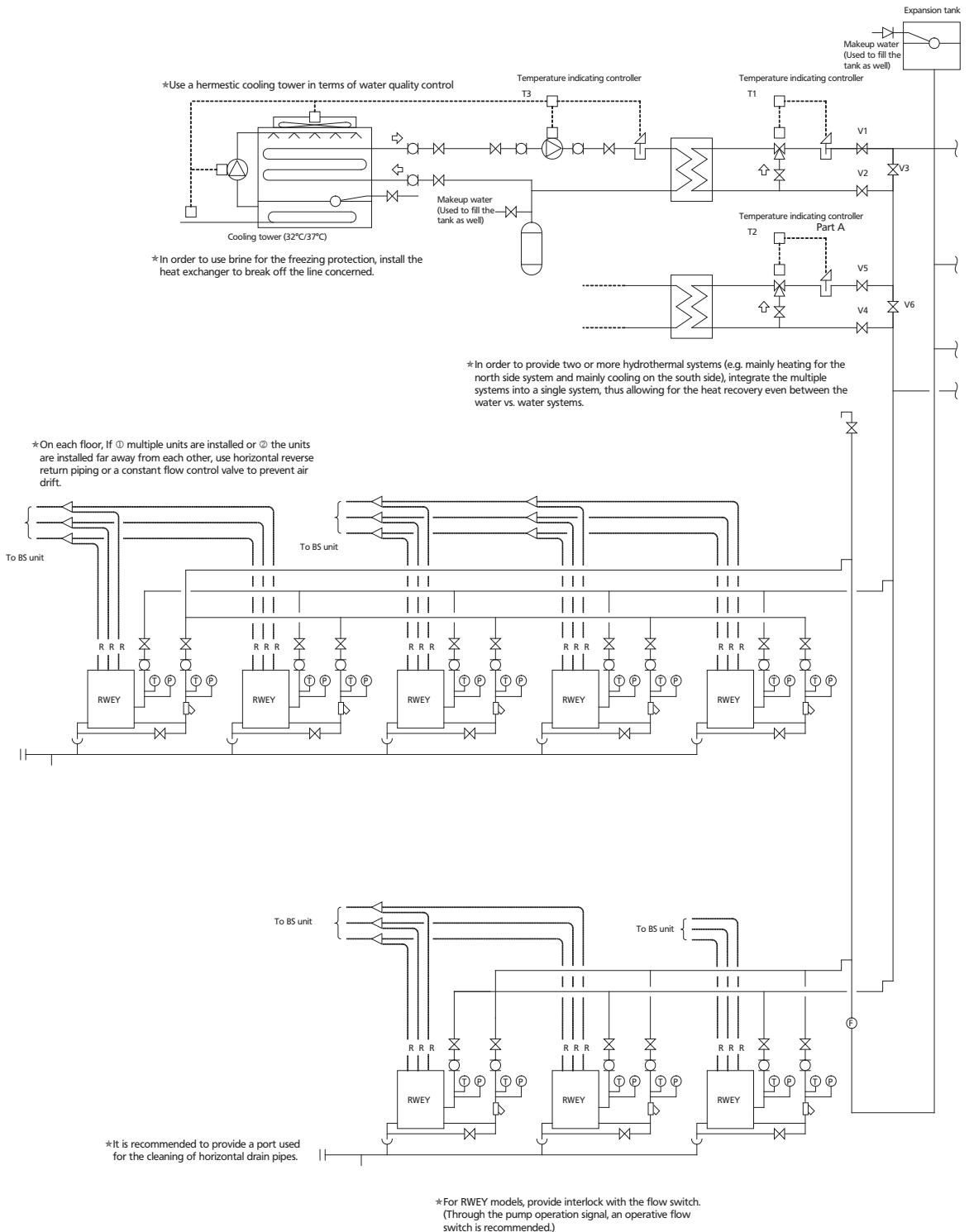

Operation mode	Cooling (mainly for cooling)	Heating (mainly for heating)	In-between seasons (cooling/heating combination)	
T1 set value	15°C		25°C	
T2 set value		40°C	20°C	
T3 set value	33°C, 31°C		33°C, 31°C	
Open/Closed of valve	V1	○	×	○
	V2	○	×	○
	V3	×	○	×
	V4	×	○	○
	V5	×	○	○
	V6	○	×	×

	Pump
	Temperature controller
	Three-way valve (mixed type)
	Y strainer
	Flexible joint
	Pressure gauge
	Thermometer
	Flow switch

9 Typical VRV®-WIII installations

9 - 4 Example Installation

(With heat recovery from multiple systems through water circuit)

Note:
 Pleased be noted that this Schematic Diagram is absolutely for reference only. Practically, construction methods may vary with projects. Therefore, consult with the architect office for the design and construction of the system.

The following section shows precautions for the design of systems, which should be thoroughly observed.

- Temperature**
 The operating range of hydrothermal cooling/heating free VRV® (RWEY) is 10°C to 45°C. Keep the water temperature in the system within the said range through the ON/OFF operation of 2-way control valve, three-way control valve, cooling tower, or boiler.
- Water quality**
 The hydrothermal cooling/heating free VRV® (RWEY) requires quality stability of water to be used. Be sure to install the hermetic cooling water or, in order to install the open type cooling water, install the heat exchanger to break off the line concerned.
- Freezing**
 Freezing protection should be provided for the cooling tower water during wintertime. Take some sort of measures shown below so that water on the primary and secondary side of the cooling water will not freeze up during wintertime.
 Typical measure: If the water temperature drops,
 Start the pump to recirculate water.
 Provide freezing protection using freezing protection heater.
 Provide water temperature drop protection through the forced startup of the boiler.
 Drain water from the cooling tower.
 Particularly, if the unit should stop for an extended period of time, it may freeze up. Consequently, attention should be paid for this point.
- Air drift**
 Provide constant amount of feed water through the installation of reverse return piping system and constant flow control valve.

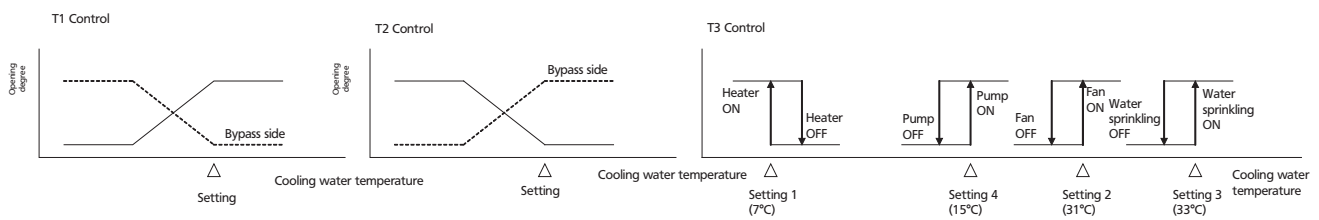
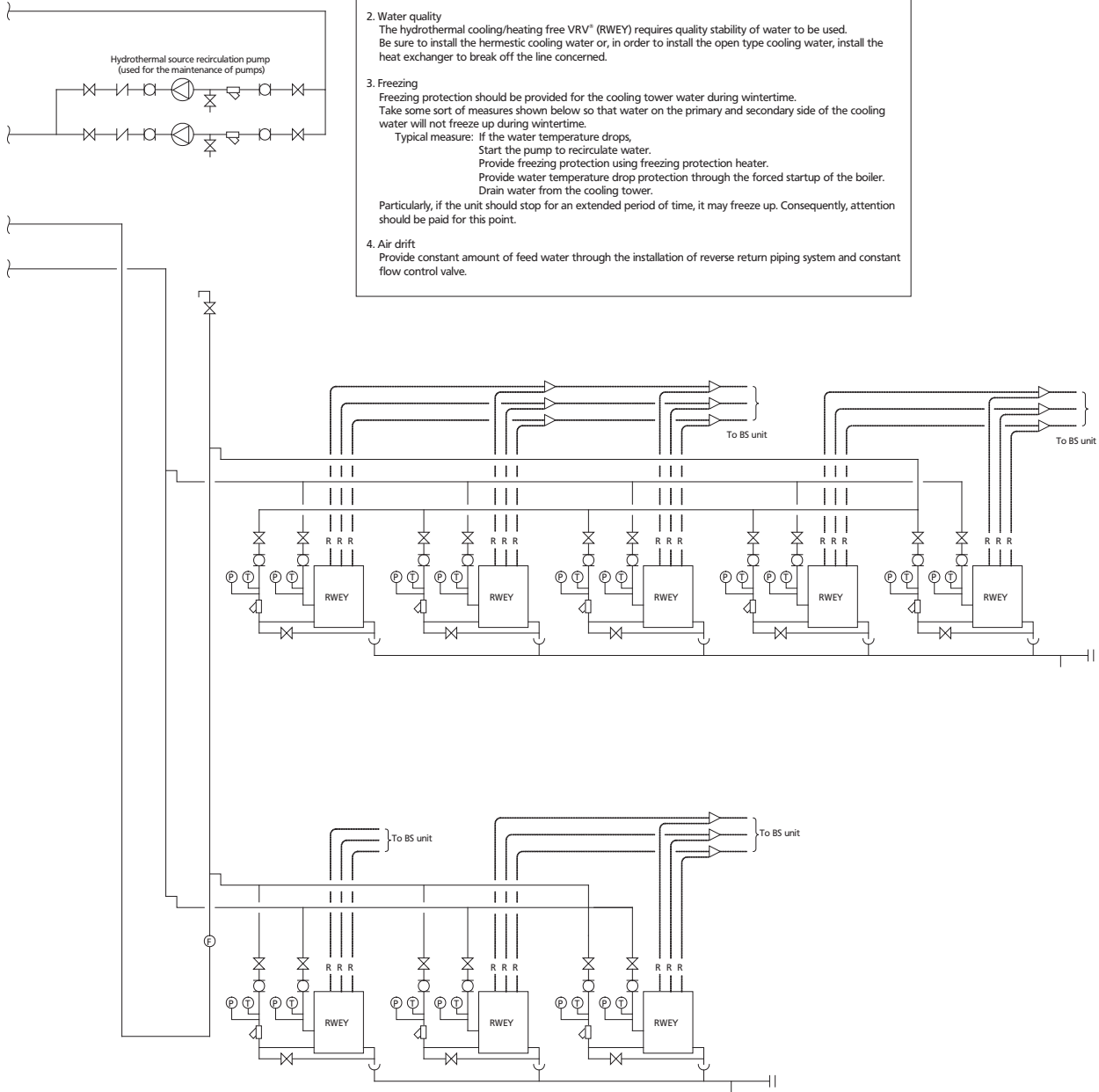

*If freezing is expected to occur, install the freezing protection heater or drain water from the water sprinkling side. (If water is drained from the water sprinkling side, pay attention so that loads will never be applied to cooling mainly.)

In all of us,
a green heart



Daikin's unique position as a manufacturer of air conditioning equipment, compressors and refrigerants has led to its close involvement in environmental issues. For several years Daikin has had the intention to become a leader in the provision of products that have limited impact on the environment. This challenge demands the eco design and development of a wide range of products and an energy management system, resulting in energy conservation and a reduction of waste.

VRV* products are not within the scope of the Eurovent certification programme.



The present publication is drawn up by way of information only and does not constitute an offer binding upon Daikin Europe N.V. Daikin Europe N.V. has compiled the content of this publication to the best of its knowledge. No express or implied warranty is given for the completeness, accuracy, reliability or fitness for particular purpose of its content and the products and services presented therein. Specifications are subject to change without prior notice. Daikin Europe N.V. explicitly rejects any liability for any direct or indirect damage, in the broadest sense, arising from or related to the use and/or interpretation of this publication. All content is copyrighted by Daikin Europe N.V.

Daikin products are distributed by:

DAIKIN EUROPE N.V. Naamloze Vennootschap - Zandvoordestraat 300, B-8400 Oostende - Belgium - www.daikin.eu - BE 0412 120 336 - RPR Oostende

EEDEN12-201 • 02/12 • Copyright Daikin
The present publication supersedes EEDEN10-201
Prepared in Belgium by Lannoo (www.lannooprint.be), a company whose concern
for the environment is set in the EMAS and ISO 14001 systems.
Responsible Editor: Daikin Europe N.V., Zandvoordestraat 300, B-8400 Oostende



Большая библиотека технической документации

<https://splitsystema48.ru/instrukcii-po-ekspluatácii-kondicionerov.html>

каталоги, инструкции, сервисные мануалы, схемы.